



WEBSITE <http://biz.LGservice.com>
E-MAIL <http://www.LGservice.com/techsup.html>

Room Air Conditioner

SERVICE MANUAL

CAUTION

- BEFORE SERVICING THE UNIT, READ THE SAFETY PRECAUTIONS IN THIS MANUAL.
- ONLY FOR AUTHORIZED SERVICE.

MODEL: WR-8030	WM-8031
WM-1031	WR-1230
WM-1231	WR-1030
HBLG8003R	HBLG1003R
R1200M	L1204R
R1200E	

CONTENTS

1. PREFACE

1.1 SAFETY PRECAUTIONS.....	2
1.2 INSULATION RESISTANCE TEST.....	2
1.3 SPECIFICATIONS.....	3
1.4 FEATURES.....	4
1.5 CONTROL LOCATIONS	4

2. DISASSEMBLY INSTRUCTIONS

2.1 MECHANICAL PARTS	6
2.1.1 FRONT GRILLE	6
2.1.2 CABINET	6
2.1.3 CONTROL BOX	6
2.2 AIR HANDLING PARTS	7
2.2.1 AIR GUIDE AND TURBO FAN.....	7
2.2.2 FAN	7
2.2.3 SHROUD	8
2.3 ELECTRICAL PARTS.....	8
2.3.1 OVERLOAD PROTECTOR	8
2.3.2 COMPRESSOR.....	8
2.3.3 CAPACITOR.....	9
2.3.4 POWER CORD	9
2.3.5 MOTOR	10
2.4 REFRIGERATION CYCLE	10
2.4.1 CONDENSER.....	10
2.4.2 EVAPORATOR.....	10
2.4.3 CAPILLARY TUBE	11

3. INSTALLATION

3.1 SELECT THE BEST LOCATION.....	13
3.2 CHECK OF INSTALLATION.....	13
3.3 HOW TO DRAIN.....	13
3.4 HOW TO INSTALL	14
3.4.1 WHEN USING GASKET.....	14
3.4.2 WHEN USING INSTALLATION KITS...14	

4. TROUBLESHOOTING GUIDE

4.1 OUTSIDE DIMENSIONS	17
4.2 PIPING SYSTEM.....	18
4.3 TROUBLESHOOTING GUIDE	19

5. SCHEMATIC DIAGRAM

5.1 CIRCUIT DIAGRAM	27
5.2 ELECTRONIC CONTROL DEVICE.....	28
5.3 COMPONENTS LOCATION(FOR MAIN P.C.B ASM) ..29	
5.4 COMPONENTS LOCATION(FOR DISPLAY P.C.B ASM) ...29	

6. EXPLODED VIEW

7. REPLACEMENT PARTS LIST

1. PREFACE

This **SERVICE MANUAL** provides various service information, including the mechanical and electrical parts etc. This room air conditioner was manufactured and assembled under a strict quality control system. The refrigerant is charged at the factory. Be sure to read the safety precautions prior to servicing the unit.

1.1 SAFETY PRECAUTIONS

1. When servicing the unit, set the **ROTARY SWITCH** or **POWER SWITCH** to **OFF** and unplug the power cord.
2. Observe the original lead dress.
If a short circuit is found, replace all parts which have been overheated or damaged by the short circuit.
3. After servicing the unit, make an insulation resistance test to protect the customer from being exposed to shock hazards.

1.2 INSULATION RESISTANCE TEST

1. Unplug the power cord and connect a jumper between 2 pins (black and white).
2. The grounding conductor (green) is to be open.
3. Measure the resistance value with an ohm meter between the jumpered lead and each exposed metallic part on the equipment at all the positions (except **OFF**) of the **ROTARY SWITCH**.
4. The value should be over **1MΩ**.

1.3 SPECIFICATIONS

1.3.1 FOR WR-8030, WM-8031, WM-1031, WR-1230, WM-1231, HBLG8003R, HBLG1003R, WR-1030, R1200M, L1204R, R1200E

ITEMS		MODELS					
		WR-8030	WM-8031 HBLG8003R	WM-1031 HBLG1003R	WR-1230 R-1200M	WM-1231 L1204R R1200E	WR1030
POWER SUPPLY		1ø, 115, 60Hz					
COOLING CAPACITY	(Btu/h)	8,000		10,000		12,000	10,000
INPUT	(W)	800		1,020		1,220	1,020
RUNNING CURRENT	(A)	7.3		9.2		11.0	9.2
E.E.R	(BTU/W.h)	10				9.8	
OPERATING CONDITION	INDOOR (°C)	26.7(DB)* 19.4(WB)**					
	OUTDOOR (°C)	35(DB)* 23.9(WB)**					
REFRIGERANT (R-22) CHARGE		300g(10.6oz)		520g(18.3oz)		470g(16.6oz)	520g(18.3oz)
EVAPORATOR		2 ROW 11STACKS		3 ROW 11STACKS		2 ROW 12STACKS	3 ROW 11STACKS
CONDENSER		2 ROW 16STACKS			2 ROW 17STACKS		2 ROW 16STACKS
FAN, INDOOR		TURBO FAN					
FAN, OUTDOOR		PROPELLER TYPE FAN WITH SLINGER RING					
FAN SPEEDS, FAN/COOLING		2/3		3/3		2/3	3/3
FAN MOTOR		6 POLES					
OPERATION CONTROL		ROTARY SWITCH	REMOTE CONTROLLER	ROTARY SWITCH	REMOTE CONTROLLER	ROTARY SWITCH	
ROOM TEMP. CONTROL		THERMOSTAT	THERMISTOR	THERMOSTAT	THERMISTOR	THERMOSTAT	
AIR DIRECTION CONTROL		VERTICAL LOUVER (RIGHT & LEFT)					
		HORIZONTAL LOUVER (UP & DOWN)					
CONSTRUCTION		SLIDE IN-OUT CHASSIS					
PROTECTOR	COMPRESSOR	OVERLOAD PROTECTOR					
	FAN MOTOR	INTERNAL THERMAL PROTECTOR					
POWER CORD		(3 WIRE WITH GROUDING)					
		ATTACHMENT PLUG (CORD-CONNECTED TYPE)					
DRAIN SYSTEM		DRAIN PIPE OR SPLASHED BY FAN SLINGER					
NET WEIGHT	(lbs/kg)	62/28					
OUTSIDE DIMENSION (W x H x D)	(inch)	20 ³ / ₃₂ X 13 ²⁹ / ₃₂ X 19 ³ / ₈					
	(mm)	510 x 354 x 490					

* DB: Dry Bulb

** WB: Wet Bulb

1.4 FEATURES

- Designed for COOLING ONLY.
- Powerful and whispering cooling.
- Slide-in and slide-out chassis for the simple installation and service.
- Low air-intake, top cooled-air discharge.

- Built-in adjustable Thermistor
- Washable one-touch filter
- Compact size
- Reliable and efficient rotary compressor is equipped.

1.5 CONTROL LOCATIONS

• THERMOSTAT

Thermostat will automatically control the temperature of the room. Select a higher number (the right side of arc) for a cooler temperature in the room. The temperature is selected by positioning the knob to the desired position. The **5** or **6** position is a normal setting for average conditions.

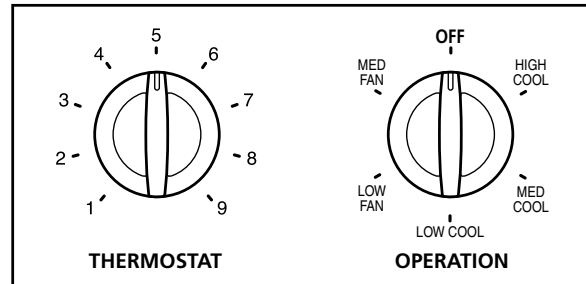

• OPERATION

- OFF** : Turns the air conditioner to off.
- MED FAN** : Permits the medium fan speed operation without cooling.
- LOW FAN** : Permits the low fan speed operation without cooling.
- HIGH COOL** : Permits cooling with the high fan speed operation.
- MED COOL** : Permits cooling with the medium fan speed operation.
- LOW COOL** : Permits cooling with the low fan speed operation.

DISPLAY

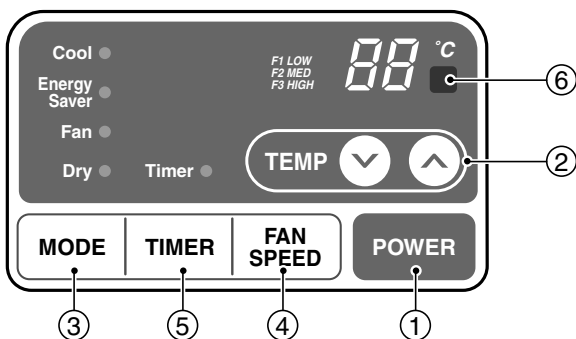

REMOTE CONTROL

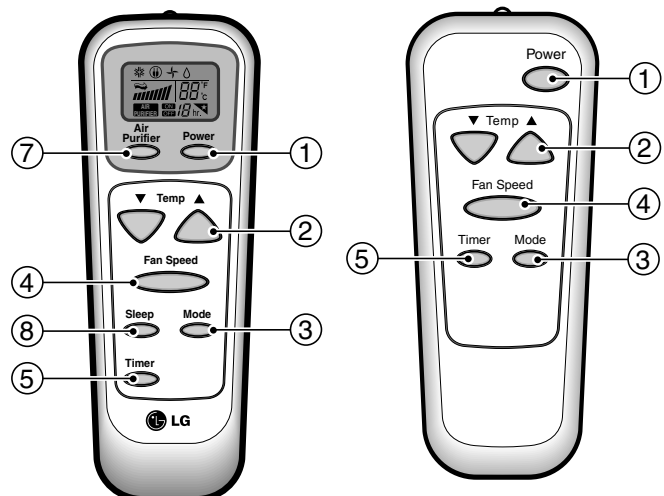

Precaution: The Remote Control unit will not function properly if strong light strikes the sensor window of the air conditioner or if there are obstacles between the Remote Control unit and the air conditioner.

1 POWER BUTTON

To turn the air conditioner ON, push the button. To turn the air conditioner OFF, push the button again.
This button takes priority over any other buttons.

2 ROOM TEMPERATURE SETTING BUTTON

This button can automatically control temperature of the room. The temperature can be set within a range of 16°C to 30°C by 1°C

Select the lower number for lower temperature of the room.

3 OPERATION MODE SELECTION BUTTON

Every time you push this button, it will shift among COOL, ENERGY SAVER, FAN and DRY.

- Energy Saver: If Energy Save mode is selected, the fan stops when the compressor stops cooling.
Approximately every 3 minutes the fan will turn on and check the room air to determine if cooling is needed.

4 FAN SPEED SELECTOR

Every time you push this button, it is set as follows.
(Hi → Low → Med → Hi → Low →...)

5 ON/OFF TIMER BUTTON

You can set the time when the unit will turn on or turn off automatically by pressing the timer button. If the unit is operating, this button controls the time it will be turned off. If the unit is off state, this button controls the time it will start. Every time you push this button, the remaining time will be set as follows.

- Stopping operation

(1Hour → 2Hours → 3Hours → 4Hours → 5Hours → 6Hours → 7Hours → 8Hours → 9Hours → 10Hours → 11Hours → 12Hours → 0Hour → 1Hour → 2Hours →...)

- Starting operation

(1Hour → 2Hours → 3Hours → 4Hours → 5Hours → 6Hours → 7Hours → 8Hours → 9Hours → 10Hours → 11Hours → 12Hours → off → 1Hour → 2Hours → ...)

6 REMOCON SIGNAL RECEIVER

7 AIR PURIFIER

- Press the Air Purifier button.
Operation will start when the button is pressed and stop when the button is pressed again.
- Set the fan speed with the remote control. You can select the fan speed in three steps high, low or medium.
Each time the button is pressed, the fan speed mode is shifted.
- If you press the only Air Purifier button, only air purifying operates.
Then, fan speed is low. You can select the fan speed in three steps high, low or medium.
Each time the button is pressed, the fan speed mode is shifted.

8 SLEEP MODE

- Press the sleep mode button to set the time you want the unit to turn off automatically.
- Every time you push this button, the remaining time will be set as follows.
(1Hour → 2Hours → 3Hours → 4Hours → 5Hours → 6Hours → 7Hours → 0Hour → 1Hour → 2Hours → ...)
- The temperature setting will be raised by 2°F in 30 minutes and by 4°F in 1 hour to prevent overcooling during sleep.

2. DISASSEMBLY INSTRUCTIONS

— Before the following disassembly, POWER SWITCH set to OFF and disconnect the power cord.

2.1 MECHANICAL PARTS

2.1.1 FRONT GRILLE

1. Open the Inlet grille downward and remove the air filter.
2. Remove the screw which fastens the front grille.(See Figure 1)
3. Pull the front grille from the right side.
4. Remove the front grille.(There are 4 hooks.)
5. Re-install the components by referring to the removal procedure, above.

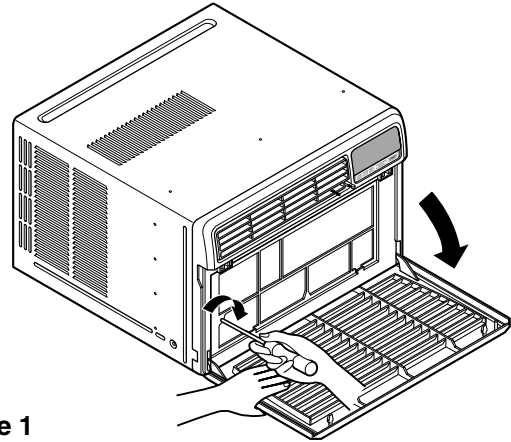

Figure 1

2.1.2 CABINET

1. After disassembling the FRONT GRILLE, remove the 2 screws which fasten the cabinet at both sides.
2. Remove the 2 screws which fasten the cabinet at back.
3. Pull the base pan forward. (See Figure 2)
4. Remove the cabinet.
5. Re-install the components by referring to the removal procedure, above.

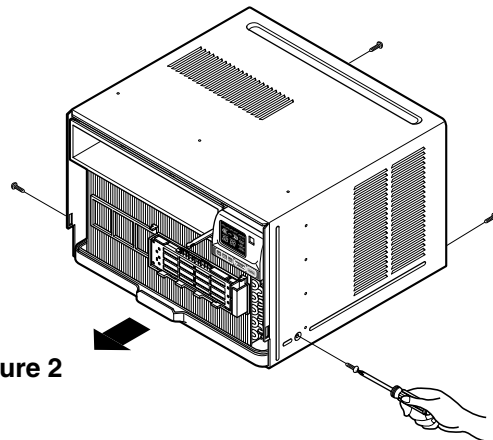

Figure 2

2.1.3 CONTROL BOX

1. Remove the front grille. (Refer to section 2.1.1)
2. Remove the cabinet. (Refer to section 2.1.2)
3. Remove the 2 screws which fasten the power cord.
4. Disconnect the grounding screw from the evaporator channel.
5. Remove the 1 screw which fasten the control box cover.
6. Remove the housing which connects PCB and motor wire in the control box.
7. Disconnect the housing which connects Plazma Air Purifier.(Optional)
8. Remove the screw at left cover of filter case and open the cover to remove inner screw. (Optional)
9. Remove the nut which fastens the terminal cover.
10. Remove the terminal cover.
11. Remove all the leads from the overload protector.
12. Discharge the capacitor by placing a 20,000 ohm resistor across the capacitor terminals.
13. Raise the control box upward completely. (See Figure 3)
14. Re-install the components by referring to the removal procedure, above. (Refer to the circuit diagram found on page 27 in this manual and on the control box.)

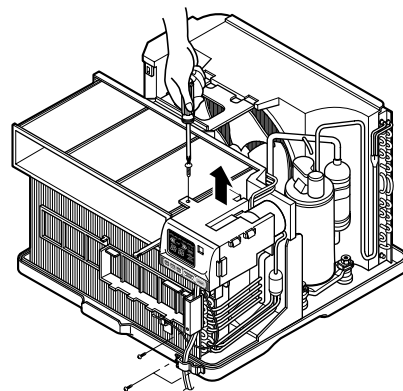

Figure 3

2.2 AIR HANDLING PARTS

2.2.1 AIR GUIDE AND TURBO FAN

1. Remove the front grille. (Refer to section 2.1.1)
2. Remove the cabinet. (Refer to section 2.1.2)
3. Remove the control box. (Refer to section 2.1.3)
4. Remove the 4 screws which fasten the brace.
5. Remove the brace.
6. Remove the 2 screws which fasten the air guide upper.
7. Remove the air guide upper. (See figure 4)
8. Remove the 2 screws which fasten the evaporator.
9. Move the evaporator forward and pulling it upward slightly. (See Figure 5)
10. Pull out the hook of orifice by pushing the tabs and remove it. (See Figure 6)
11. Remove the clamp with a hand plier which secures the turbo fan.
12. Remove the turbo fan.
13. Remove the 2 screws which fasten the air guide from the base pan.
14. Move the air guide backward, and pull out from the base pan. (Move the air guide lower carefully.)
15. Re-install the components by referring to the removal procedure, above.

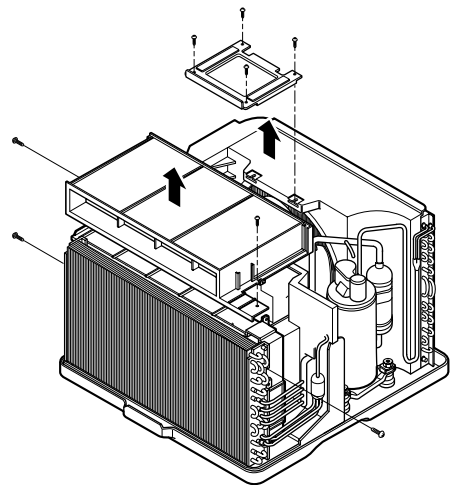

Figure 4

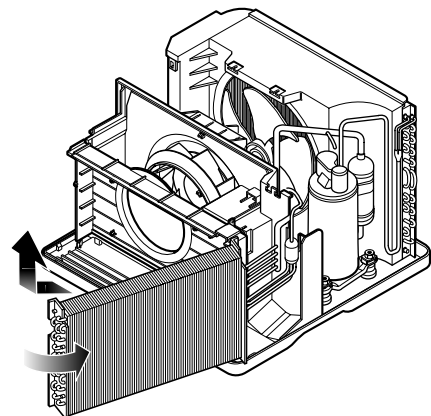

Figure 5

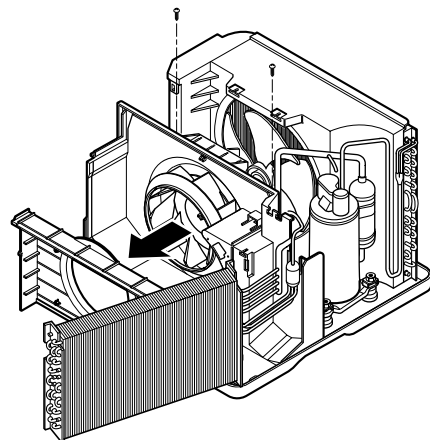

Figure 6

2.2.2 FAN

1. Remove the cabinet. (Refer to section 2.1.2)
2. Remove the brace (Refer to section 2.2.1)
3. Remove the 5 screws which fasten the condenser.
4. Move the condenser to the left carefully.
5. Remove the clamp which secures the fan.
6. Remove the fan. (See Figure 7)
7. Re-install by referring to the removal procedure.

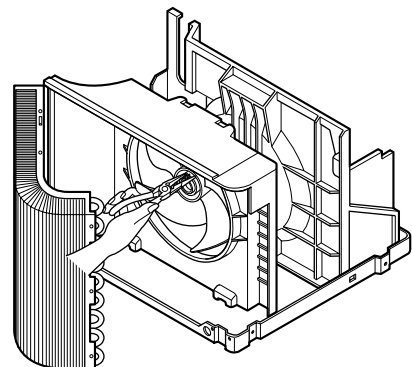

Figure 7

2.2.3 SHROUD

1. Remove the fan. (Refer to section 2.2.2)
2. Remove the shroud. (See Figure 8)
3. Re-install the components by referring to the removal procedure, above.

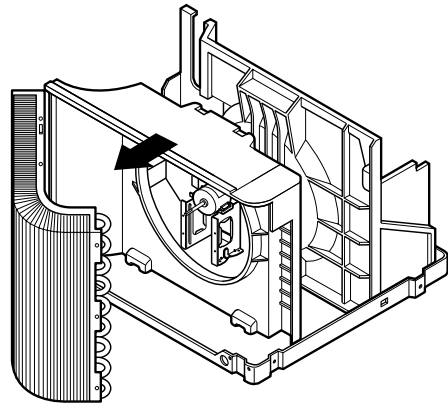

Figure 8

2.3 ELECTRICAL PARTS

2.3.1 OVERLOAD PROTECTOR

1. Remove the cabinet. (Refer to section 2.1.2)
2. Remove the nut which fastens the terminal cover.
3. Remove the terminal cover. (See Figure 9)
4. Remove all the leads from the overload protector.
5. Remove the overload protector.
6. Re-install the components by referring to the removal procedure, above.

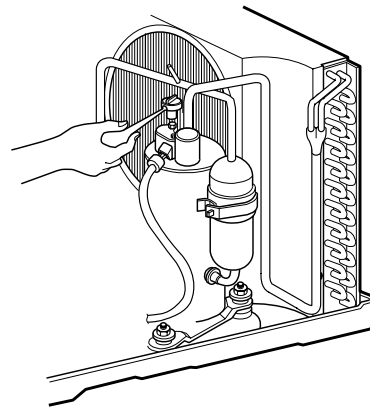

Figure 9

2.3.2 COMPRESSOR

1. Remove the cabinet. (Refer to section 2.1.2)
2. Discharge the refrigerant system using a Freon™ Recovery System.
If there is no valve to attach the recovery system, install one (such as a WATCO A-1) before venting the Freon™. Leave the valve in place after servicing the system.
3. Remove the overload protector. (Refer to section 2.3.1)
4. After purging the unit completely, unbraid the suction and discharge tubes at the compressor connections.
5. Remove the 3 nuts and the 3 washers which fasten the compressor.
6. Remove the compressor. (See Figure 10)
7. Re-install the components by referring to the removal procedure, above.

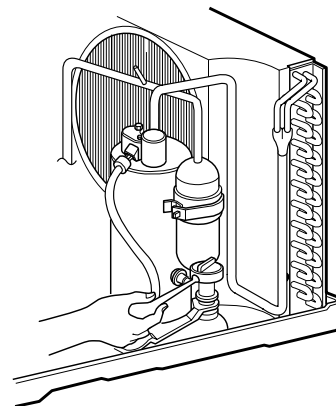

Figure 10

2.3.3 CAPACITOR

1. Remove the control box. (Refer to section 2.1.3)
2. Open the top cover from the control box.
(See Figure 11)
3. Pull out the capacitor from the control box.
4. Disconnect all the leads of capacitor terminals.
5. Re-install the components by referring to the removal procedure, above.

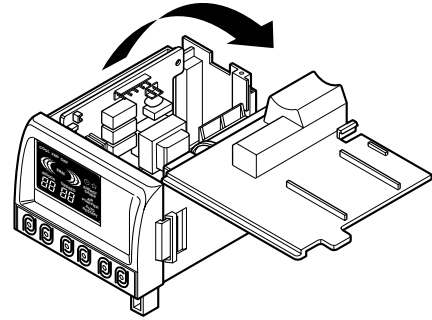

Figure 11

2.3.4 POWER CORD

1. Remove the control box. (Refer to section 2.1.3)
2. Open the top cover from the control box.
(Refer to section 2.3.3)
3. Disconnect the front panel from the control box.
(See Figure 12)
4. Disconnect two leads from the capacitor and relay.
5. Pull out the power cord.
6. Re-install the component by referring to the above removal procedure, above.
(Use only one ground-marked hole for ground connection.)
7. If the supply cord of this appliance is damaged, it must be replaced by the special cord.
(The special cord means the cord which has the same specification marked on the supply cord attached at the unit.)

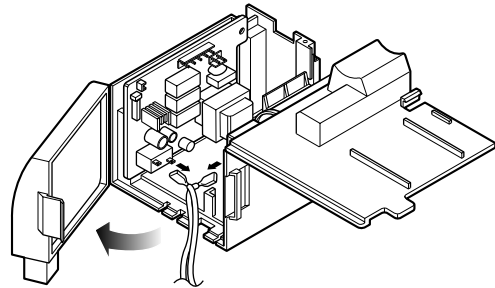
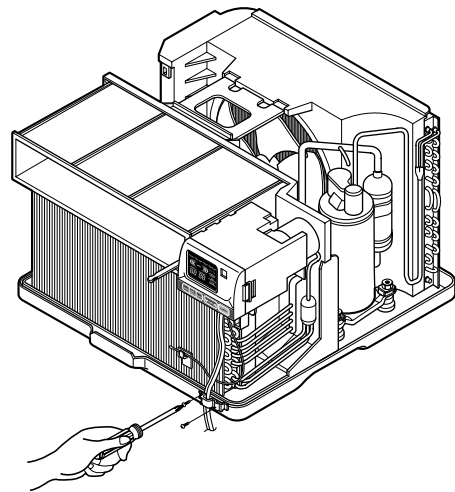

Figure 12

2.3.5 MOTOR

1. Remove the cabinet. (Refer to section 2.1.2)
2. Remove the turbo fan. (Refer to section 2.2.1)
3. Remove the fan. (Refer to section 2.2.2)
4. Remove the 4 screws which fasten the motor from the air guide. (See Figure 13)
5. Remove the motor.
6. Re-install the components by referring to the removal procedure, above.(See Figure 13)

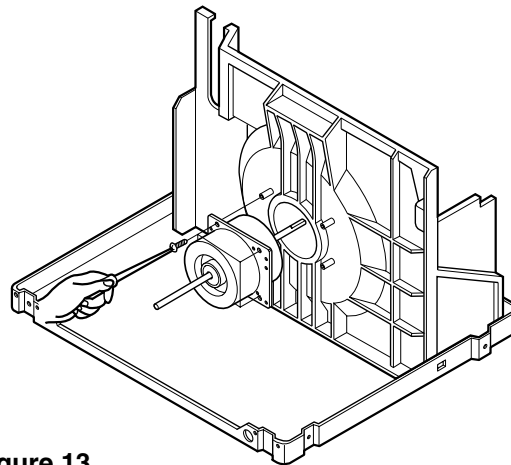

Figure 13

2.4 REFRIGERATING CYCLE

2.4.1 CONDENSER

CAUTION

Discharge the refrigerant system using a Freon™ Recovery System. If there is no valve to attach the recovery system, install one (such as a WATCO A-1) before venting the Freon™. Leave the valve in place after servicing the system.

1. Remove the cabinet. (Refer to section 2.1.2)
2. Remove the 5 screws which fasten the brace.(Refer to section 2.2.1)
3. Remove the 5 screws which fasten the condenser and shroud.
4. After discharging the refrigerant completely, unbrazed the interconnecting tube at the condenser connections.
5. Remove the condenser.
6. Re-install the components by referring to notes. (See Figure 14)

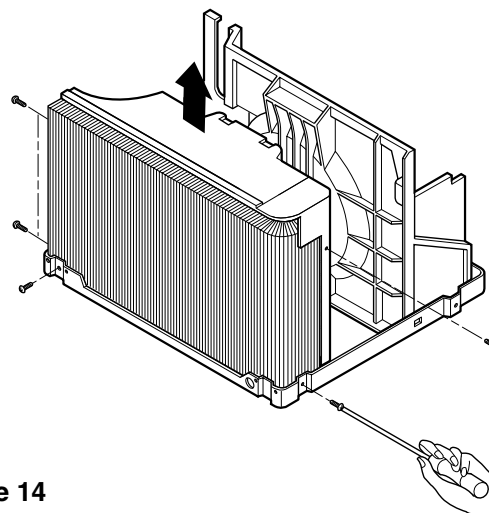

Figure 14

2.4.2 EVAPORATOR

1. Remove the control box.(Refer to section 2.1.3)
2. Remove the air guide upper. (Refer to section 2.2.1)
3. Remove the 2 screws which fasten the evaporator.
4. Move the evaporator sideways carefully. (Refer to section 2.2.1)
5. After discharging the refrigerant completely, unbrazed the interconnecting tube at the evaporator connections.
6. Remove the evaporator.
7. Re-install the components by referring to notes. (See Figure 15)

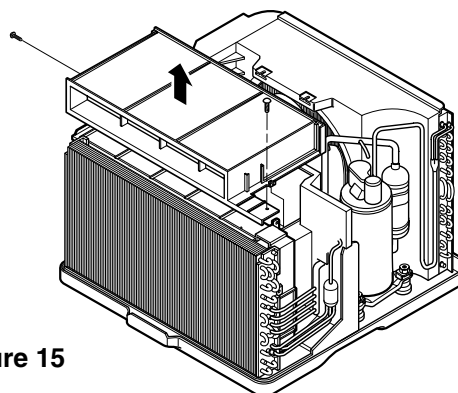

Figure 15

2.4.3 CAPILLARY TUBE

1. Remove the cabinet. (Refer to section 2.1.2)
2. After discharging the refrigerant completely, unbraid the interconnecting tube at the capillary tube. (See caution above)
3. Remove the capillary tube.
4. Re-install the components by referring to notes.

NOTES

— Replacement of the refrigeration cycle.

1. When replacing the refrigeration cycle, be sure to Discharge the refrigerant system using a Freon™ recovery System.
If there is no valve to attach the recovery system, install one (such as a WATCO A-1) before venting the Freon™. Leave the valve in place after servicing the system.
 2. After discharging the unit completely, remove the desired component, and unbraid the pinch-off tubes.
 3. Solder service valves into the pinch-off tube ports, leaving the valves open.
 4. Solder the pinch-off tubes with Service valves.
 5. Evacuate as follows.
 - 1) Connect the vacuum pump, as illustrated figure 16A.
 - 2) Start the vacuum pump, slowly open manifold valves A and B with two full turns counterclockwise and leave the valves open. The vacuum pump is now pulling through valves A and B up to valve C by means of the manifold and entire system.
 6. Recharge as follows :
 - 1) Refrigeration cycle systems are charged from the High-side. If the total charge cannot be put in the High-side, the balance will be put in the suction line through the access valve which you installed as the system was opened.
 - 2) Connect the charging cylinder as shown in figure 16B.
With valve C open, discharge the hose at the manifold connection.
 - 3) Open valve A and allow the proper charge to enter the system. Valve B is still closed.
 - 4) If more charge is required, the high-side will not take it. Close valve A.
 - 5) With the unit running, open valve B and add the balance of the charge.
 - a. Do not add the liquid refrigerant to the Low-side.
 - b. Watch the Low-side gauge; allow pressure to rise to 30 lbs.
 - c. Turn off valve B and allow pressure to drop.
 - d. Repeat steps b. and c. until the balance of the charge is in the system.
 - 6) When satisfied the unit is operating correctly, use the pinch-off tool with the unit still running and clamp on to the pinch-off tube. Using a tube cutter, cut the pinch-off tube about 2 inches from the pinch-off tool. Use sil-fos solder and solder pinch-off tube closed. Turn off the unit, allow it to set for a while, and then test the leakage of the pinch-off connection.
- 3) Operate the vacuum pump for 20 to 30 minutes, until 600 microns of vacuum is obtained. Close valves A and B, and observe vacuum gauge for a few minutes. A rise in pressure would indicate a possible leak or moisture remaining in the system. With valves A and B closed, stop the vacuum pump.
 - 4) Remove the hose from the vacuum pump and place it on the charging cylinder. See figure 16B.
Open valve C.
Discharge the line at the manifold connection.
 - 5) The system is now ready for final charging.

CAUTION

If high vacuum equipment is used, just crack valves A and B for a few minutes, then open slowly with the two full turns counterclockwise. This will keep oil from foaming and being drawn into the vacuum pump.

Equipment needed: Vacuum pump, Charging cylinder, Manifold gauge, Brazing equipment. Pin-off tool capable of making a vapor-proof seal, Leak detector, Tubing cutter, Hand Tools to remove components, Service valve.

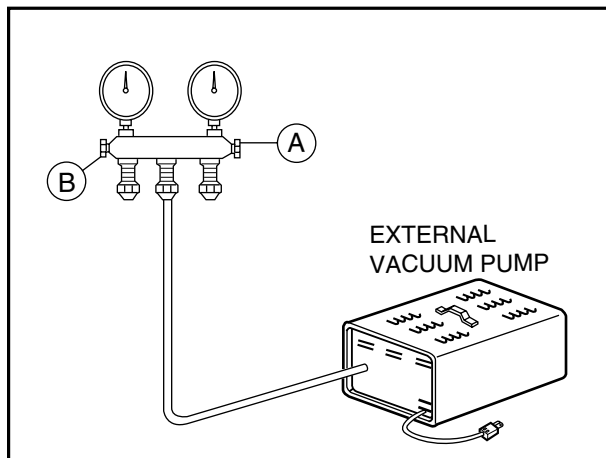
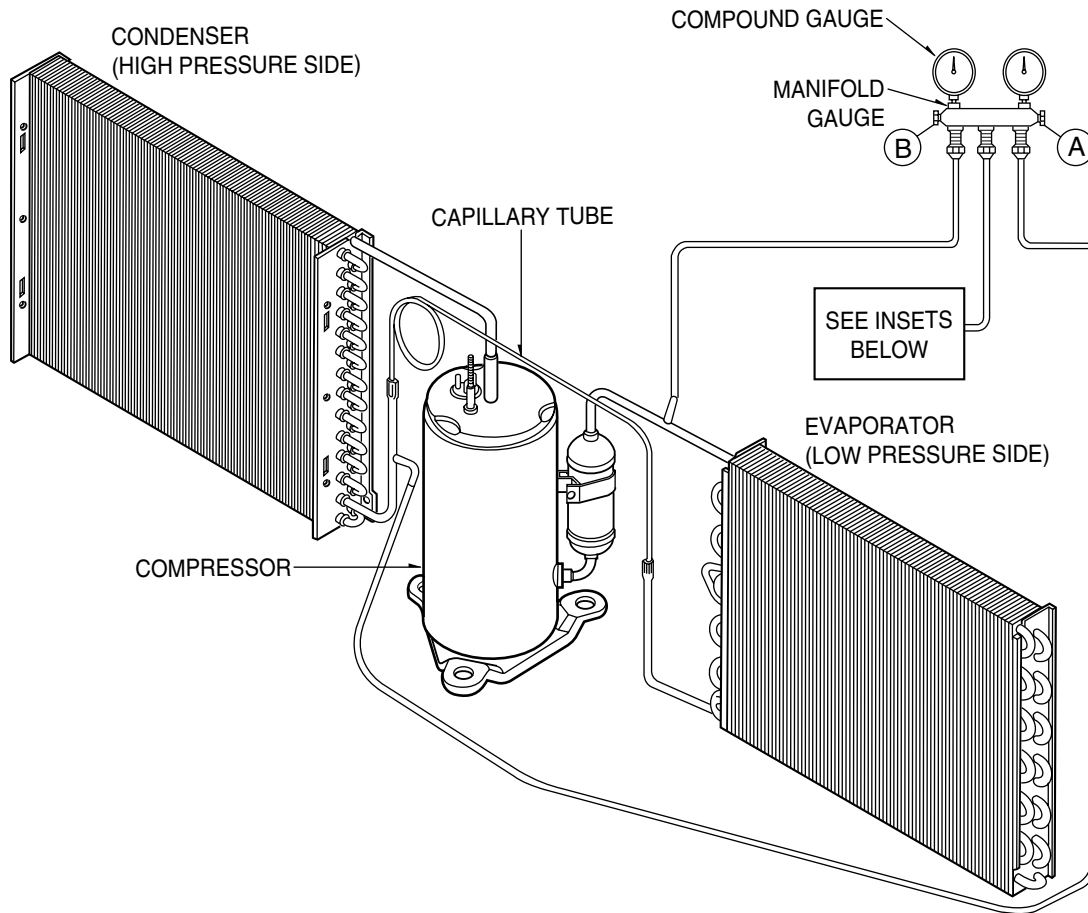

Figure 16A-Pulling Vacuum

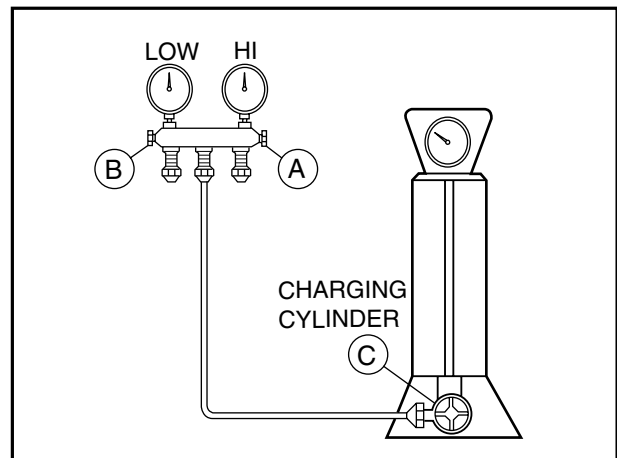

Figure 16B-Charging

3. INSTALLATION

3.1 SELECT THE BEST LOCATION

1. To prevent vibration and noise, make sure the unit is installed securely and firmly.
2. Install the unit where the sunlight does not shine directly on the unit.
3. The outside of the cabinet must extend outward for at least 12" and there should be no obstacles, such as a fence or wall, within 20" from the back of the cabinet because it will prevent heat radiation of the condenser. Restriction of outside air will greatly reduce the cooling efficiency of the air conditioner.

CAUTION

All side louvers of the cabinet must remain exposed to the outside of the structure.

4. Install the unit a little slanted so the back is slightly lower than the front (about 1/2"). This will help force condensed water to the outside.
5. Install the unit from the bottom about 30"~60" above the floor level.

3.2 CHECK OF INSTALLATION

The setting conditions must be checked prior to initial starting.

The undermentioned items are especially important checking points when the installation is finished.

1. Grounding wire (Green or Green and Yellow) is provided in the power cord. The green wire must be grounded.
2. Connect to a single-outlet 15A circuit. (or 20A circuit for Electric Heater Model)
3. To avoid vibration or noise, make sure the air conditioner is installed securely.
4. Avoid placing furniture or draperies in front of the air inlet and outlet.

3.3. HOW TO DRAIN (When using drain pipe)

The air conditioner must be installed horizontally or tilted slightly to the outside for proper water drainage.

On exceptionally hot and humid days the air conditioner may overflow condensed water.

If the air conditioner is used in hot and a high humidity zone, exchange the ① HOLE RUBBER for the ② DRAIN PIPE. (See figure 18, figure 19.)

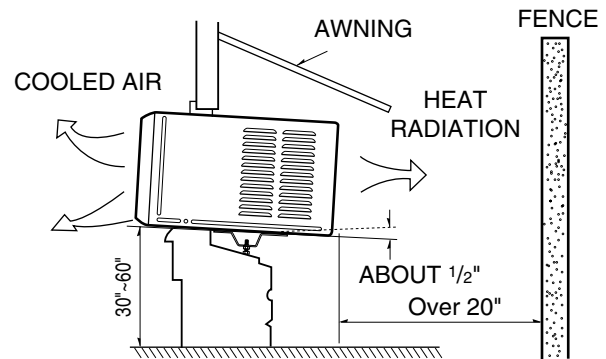

Figure 17

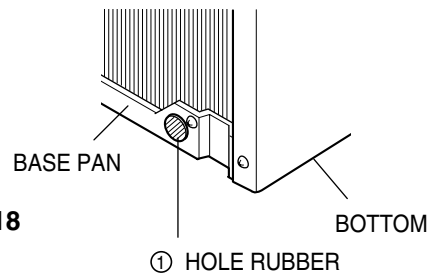

Figure 18

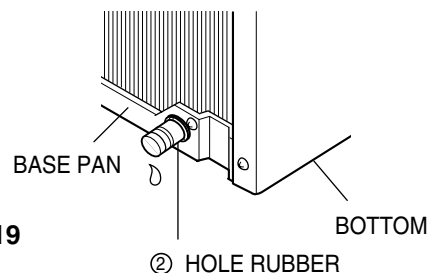
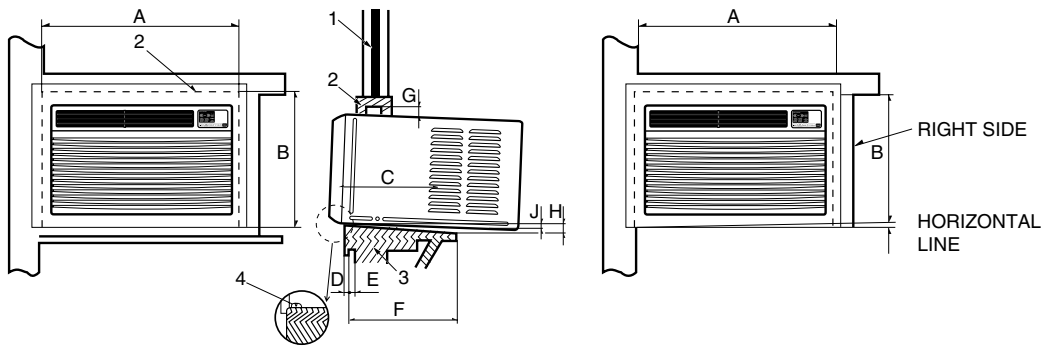

Figure 19

3.4 HOW TO INSTALL

3.4.1 WHEN USING GASKET



- 1. WINDOW (WIDTH-A, HEIGHT-B)
- 2. GASKET
- 3. WALL

- 4. DETAILS 5.1 x 30 ROUND HEAD WOOD SCREWS

A	B	C	D	E	F	H	J	K
535mm (21½")	366mm (147/16")	250mm (10")	30mm (1¼")	0~25mm (0~1")	OVER 420mm (OVER 1617/32")	32 (1¼")	5~10mm (3/16"~3/8")	0~5mm (0~3/16")

3.4.2 WHEN USING INSTALLATION KITS

A. WINDOW REQUIREMENTS

This unit is designed for installation in standard double hung windows with actual opening widths from 25" to 36".

The top and bottom window sash must open sufficiently to allow a clear vertical opening of 16" from the bottom of the upper sash to the window stool.

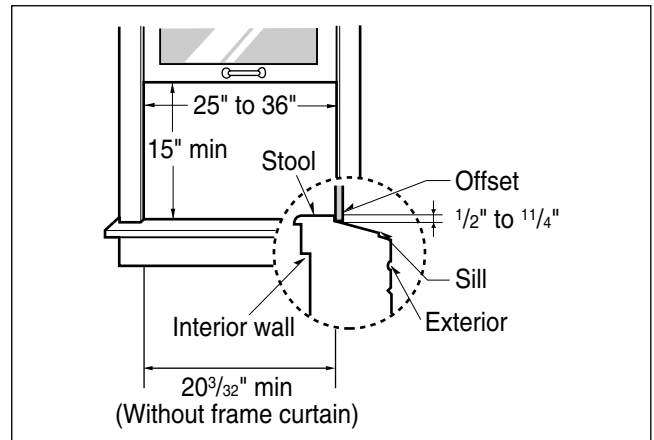

B. INSTALLATION KITS CONTENTS

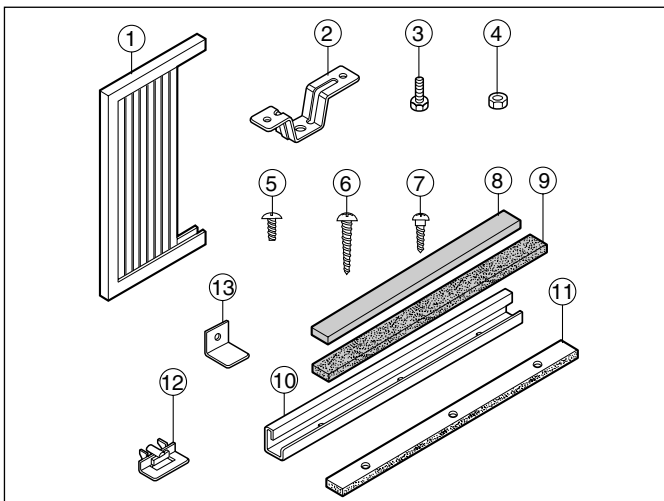

NO.	NAME OF PARTS	Q'TY
1	FRAME CURTAIN	2
2	SILL SUPPORT	2
3	BOLT	2
4	NUT	2
5	SCREW(TYPE A)	16
6	SCREW(TYPE B)	3
7	SCREW(TYPE C)	5
8	FOAM-STRIP	1
9	FOAM-PE	1
10	UPPER GUIDE	1
11	FOAM-PE	1
12	FRAME GUIDE	2
13	WINDOW LOCKING BRACKET	1

SUGGESTED TOOL REQUIREMENTS

SCREWDRIVER(+, -), RULER, KNIFE, HAMMER, PENCIL, LEVEL

PREPARATION OF CHASSIS

1. Remove the screws which fasten the cabinet at both sides and at the back.
2. Slide the unit out from the cabinet by gripping the base pan handle and pulling forward while bracing the cabinet.
3. Cut the window sash seal to the proper length. Peel off the backing and attach the Foam-Pe ⑨ to the underside of the window sash.
4. Remove the backing from the top upper guide Foam PE ⑪ and attach it to the bottom of the Upper Guide ⑩.
5. Attach the upper guide onto the top of the cabinet with 3 type A screws.
6. Insert the Frame Guides ⑫ into the bottom of the cabinet.
7. Insert the Frame Curtain ① into the upper guide ⑩ and Frame Guides ⑫.
8. Fasten the curtains to the unit with 4 Type A screws at the both sides.

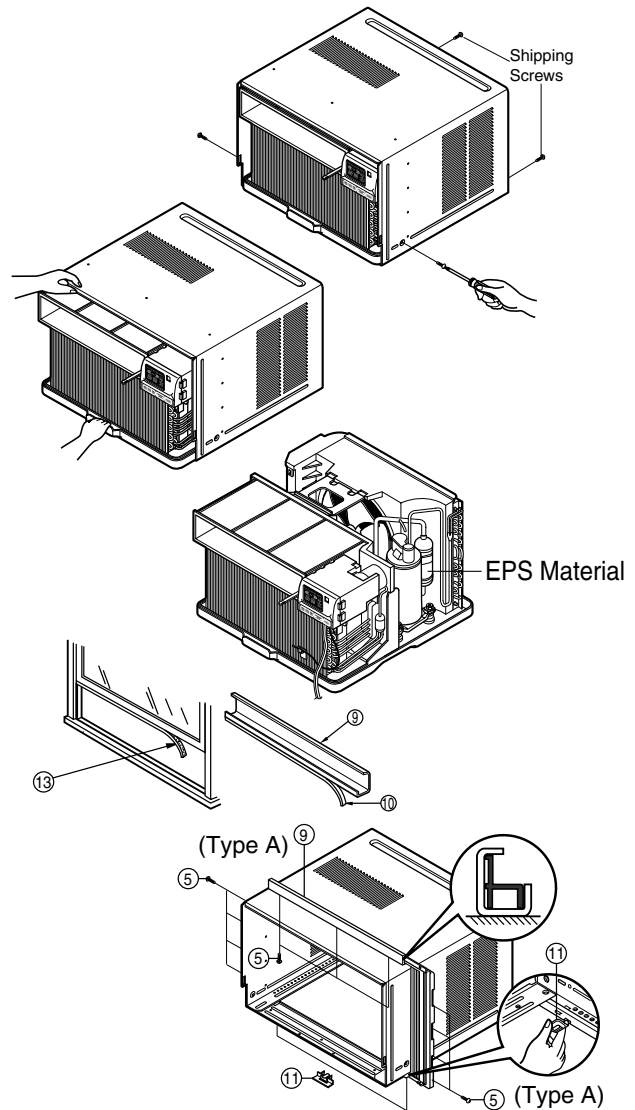

CABINET INSTALLATION

1. Open the window. Mark a line on center of the window stool (or desired air conditioner location). Carefully place the cabinet on the window stool and align the center mark on the front angle with the center line marked in the window stool.
2. Pull the bottom window sash down behind the upper guide until it meets.

NOTE:

- Do not pull the window sash down so tightly that the movement of Frame Curtain ① is restricted.

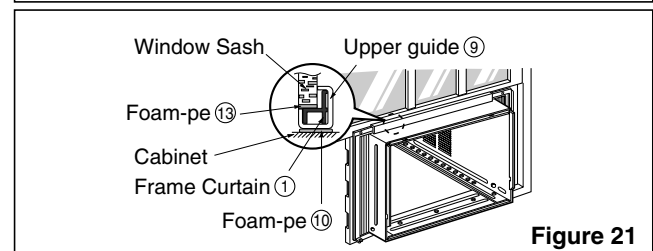
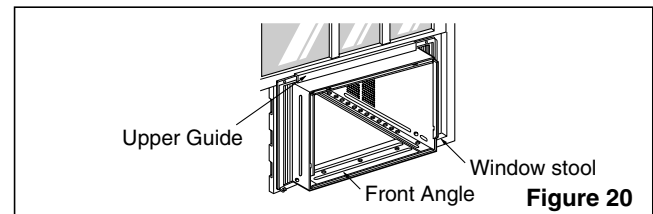

3. Loosely assemble the sill support using the parts in Figure 22.

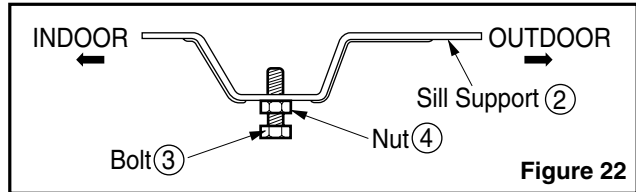

4. Select the position that will place the sill support near the outer most point on sill (See Figure 22)

NOTE: Be careful when you install the cabinet (Frame Guides 12 are broken easily).

5. Attach the sill support to the cabinet track hole in relation to the selected position using 2 Type A screws in each support (See Figure 23).

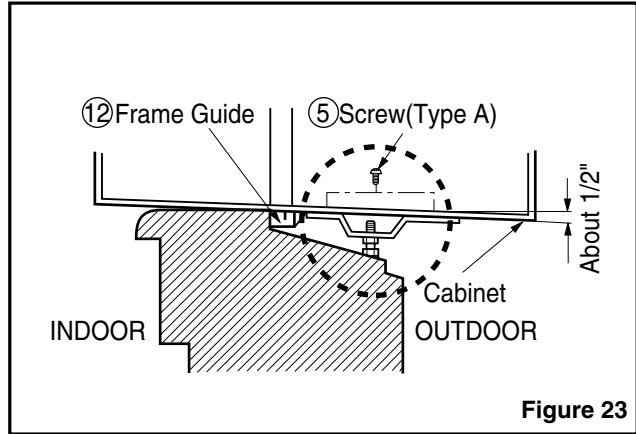

6. The cabinet should be installed with a very **slight tilt (about 1/2") downward** toward the outside (See Figure 24).
Adjust the bolt and the nut of Sill Support 2 for balancing the cabinet.

7. Attach the cabinet to the window stool by driving the screws 6 (Type B: Length sixteen millimeters and below.) through the front angle into window stool (5/8").

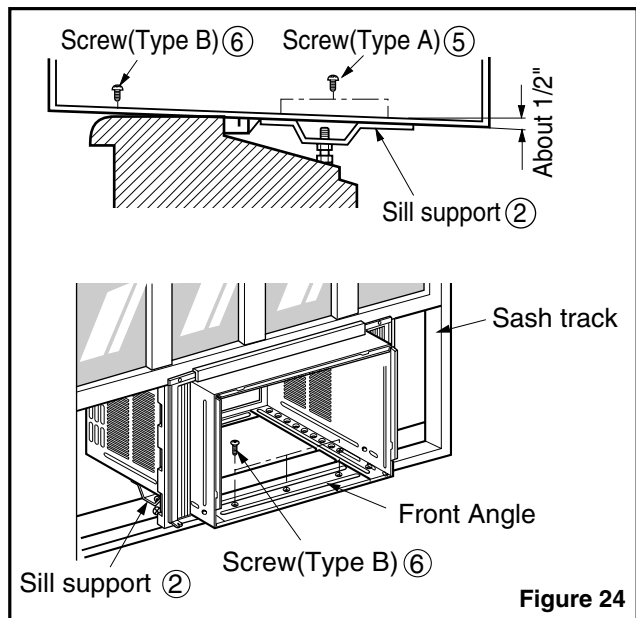

8. Pull each Frame Curtain 1 properly to each window sash track, and repeat step 2.

9. Attach each Frame Curtain 1 to the window sash by using screws 7 (Type C). (See Figure 25)

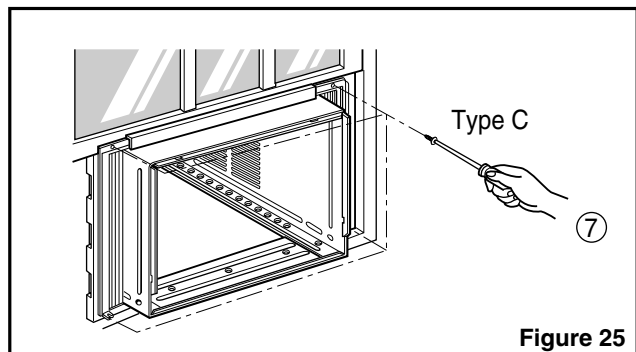

10. Slide the unit into the cabinet.(See Fig. 26)

CAUTION: For security purpose, reinstall screws (Type A) at the cabinet's sides.

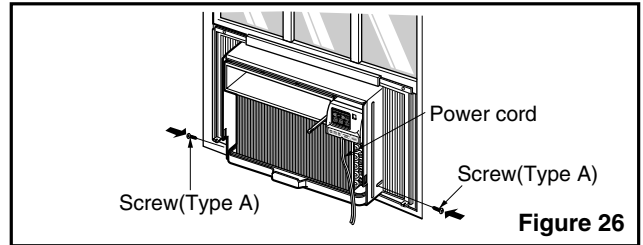

Figure 26

11. Cut the Foam-Strip ⑧ to the proper length and insert between the upper and lower window sash. (See Fig. 27)

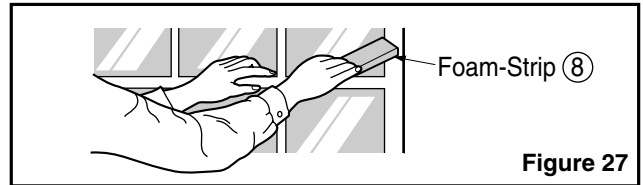

Figure 27

12. Attach the window Locking Bracket ⑬ with a type C screw. (See Fig. 28)

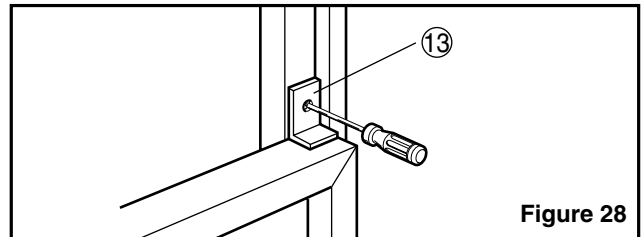

Figure 28

13. Attach the front grille to the cabinet by inserting the tabs on the grille into the tabs on the front of the cabinet. Push the grille in until it snaps into place.(See Fig. 29)

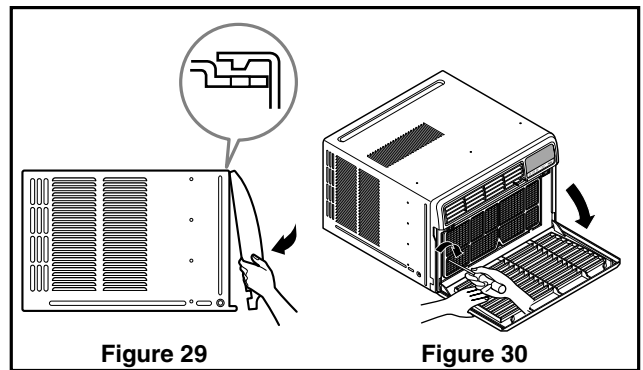

Figure 29

Figure 30

14. Lift the inlet grille and secure it with a type A screw through the front grille.(See Fig. 30)

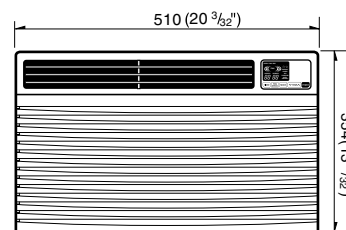
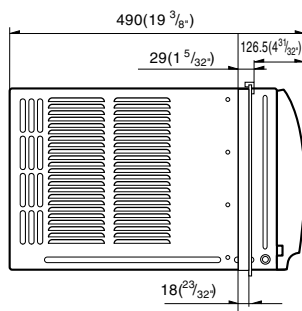

Figure 31

4. TROUBLESHOOTING GUIDE

4.1 OUTSIDE DIMENSIONS

unit: mm(inch)



4.2 PIPING SYSTEM

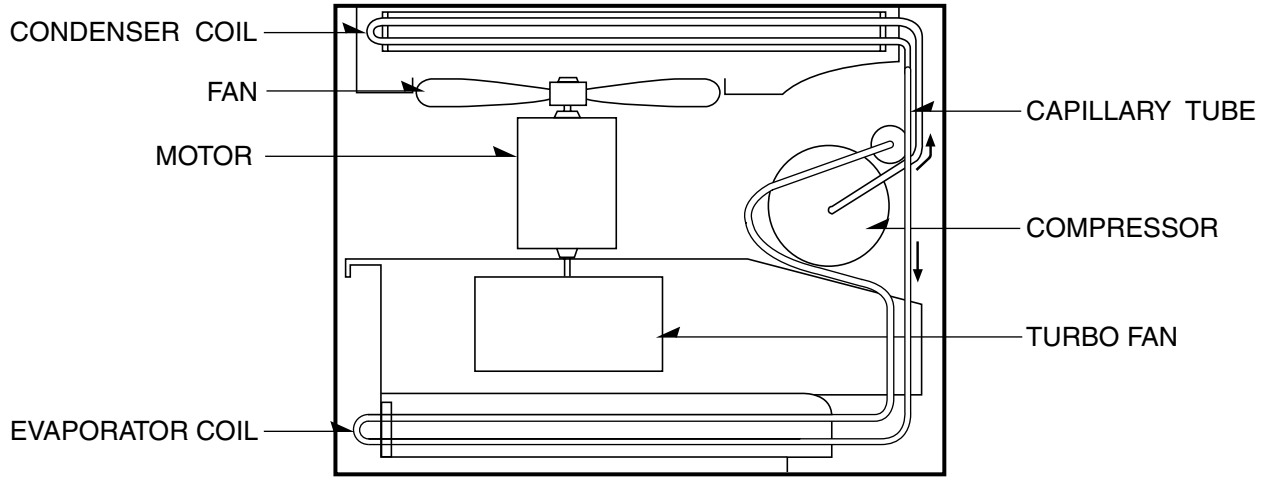
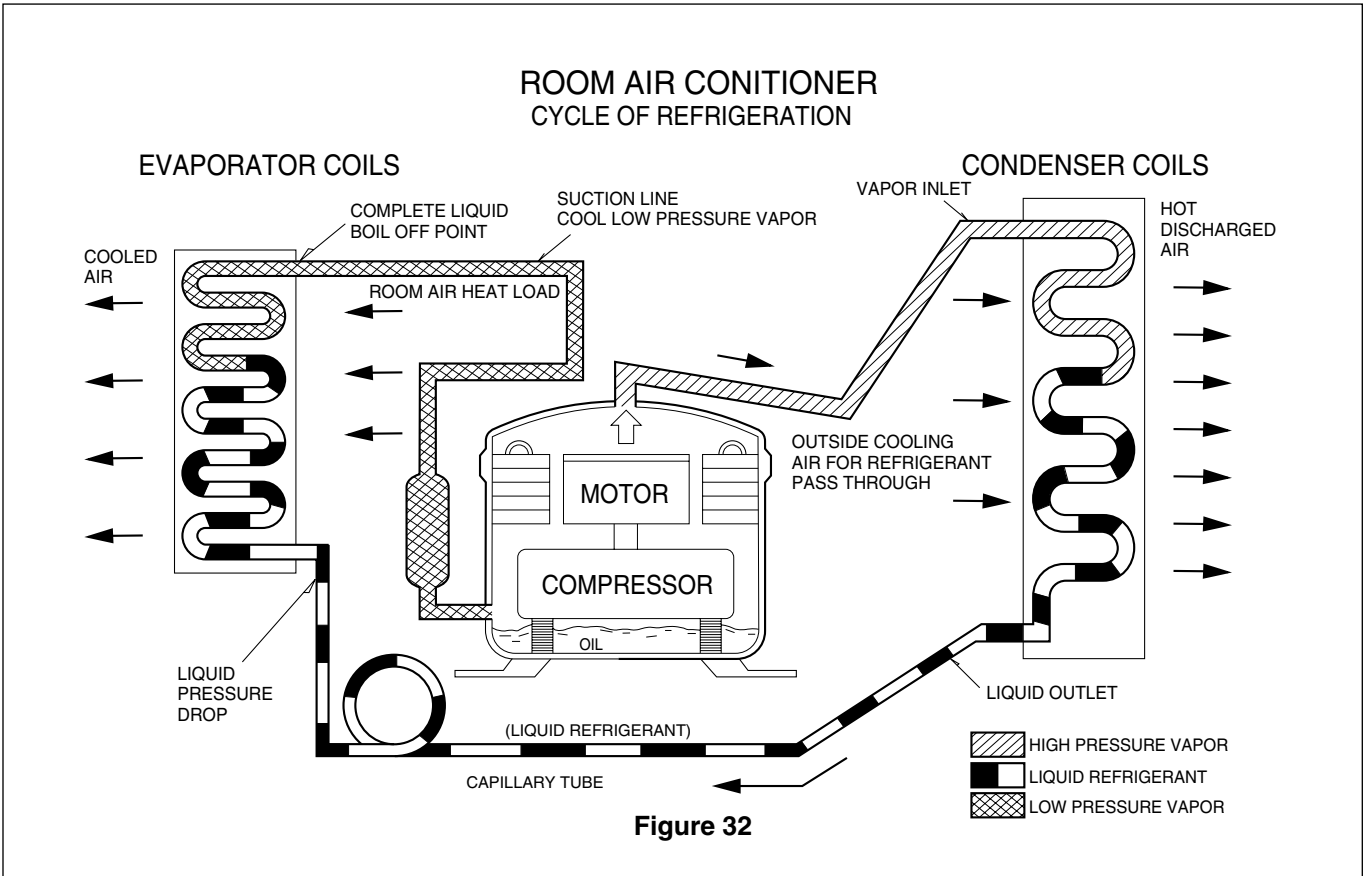

Figure 32 is a brief description of the important components and their function in what is called the refrigeration system. This will help you to understand the refrigeration cycle and the flow of the refrigerant in the cooling cycle.



4.3 TROUBLESHOOTING GUIDE

In general, possible trouble is classified in two kinds.

The one is called Starting Failure which is caused from an electrical defect, and the other is ineffective Air Conditioning caused by a defect in the refrigeration circuit and improper application.

Unit runs but poor cooling.

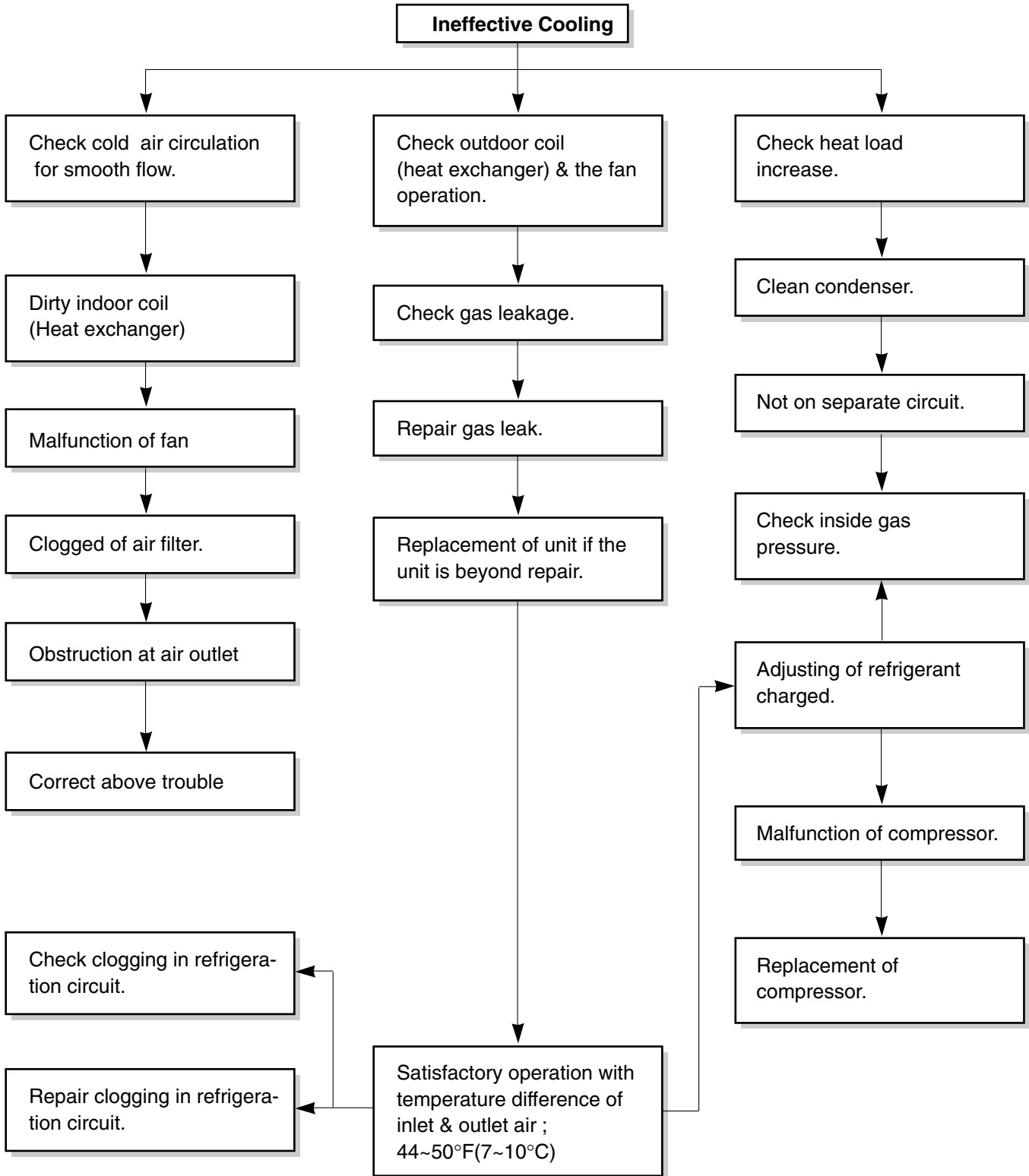

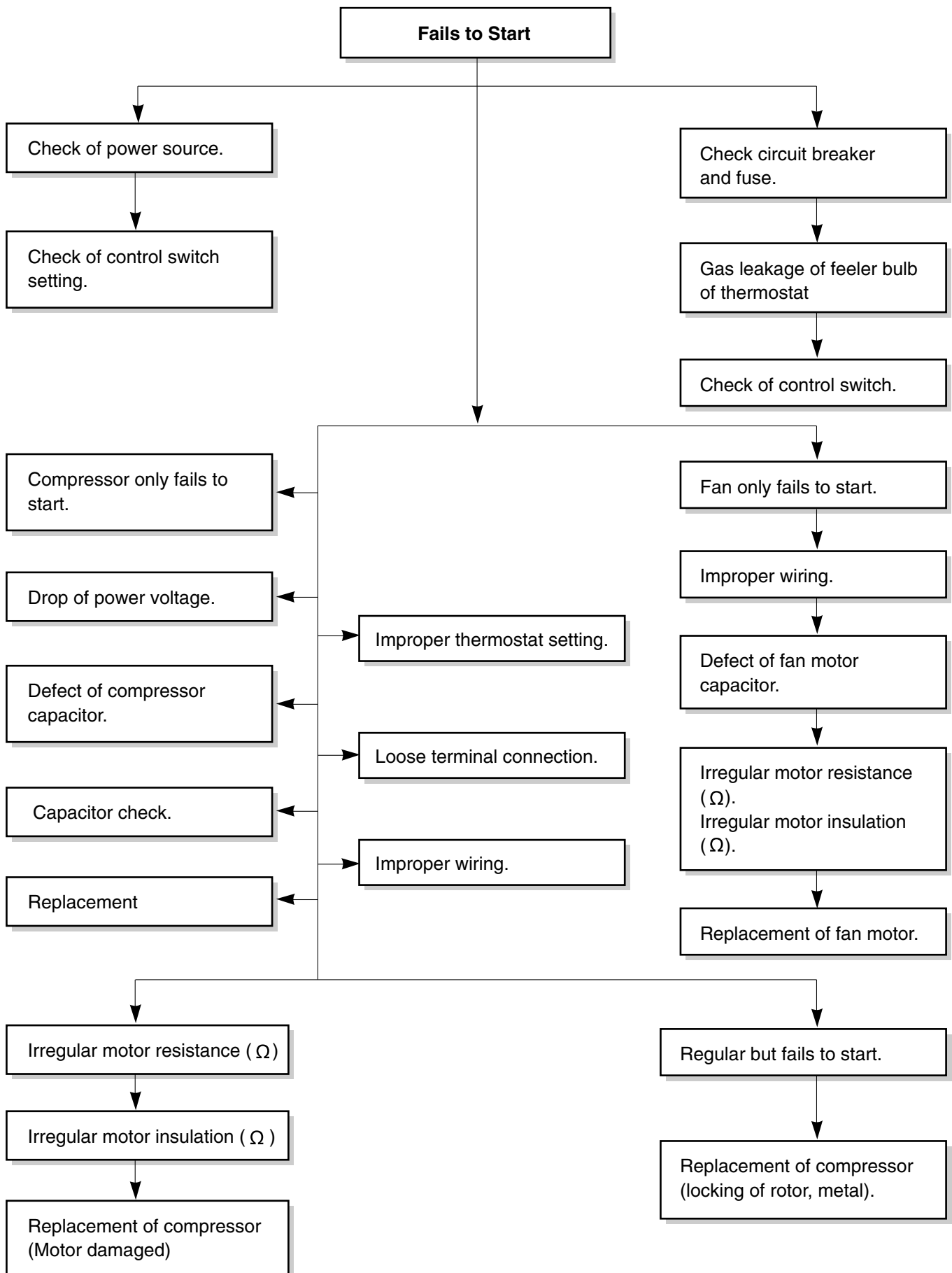

■ ELECTRICAL PARTS TROUBLESHOOTING GUIDE: WM-8031, WM-1031

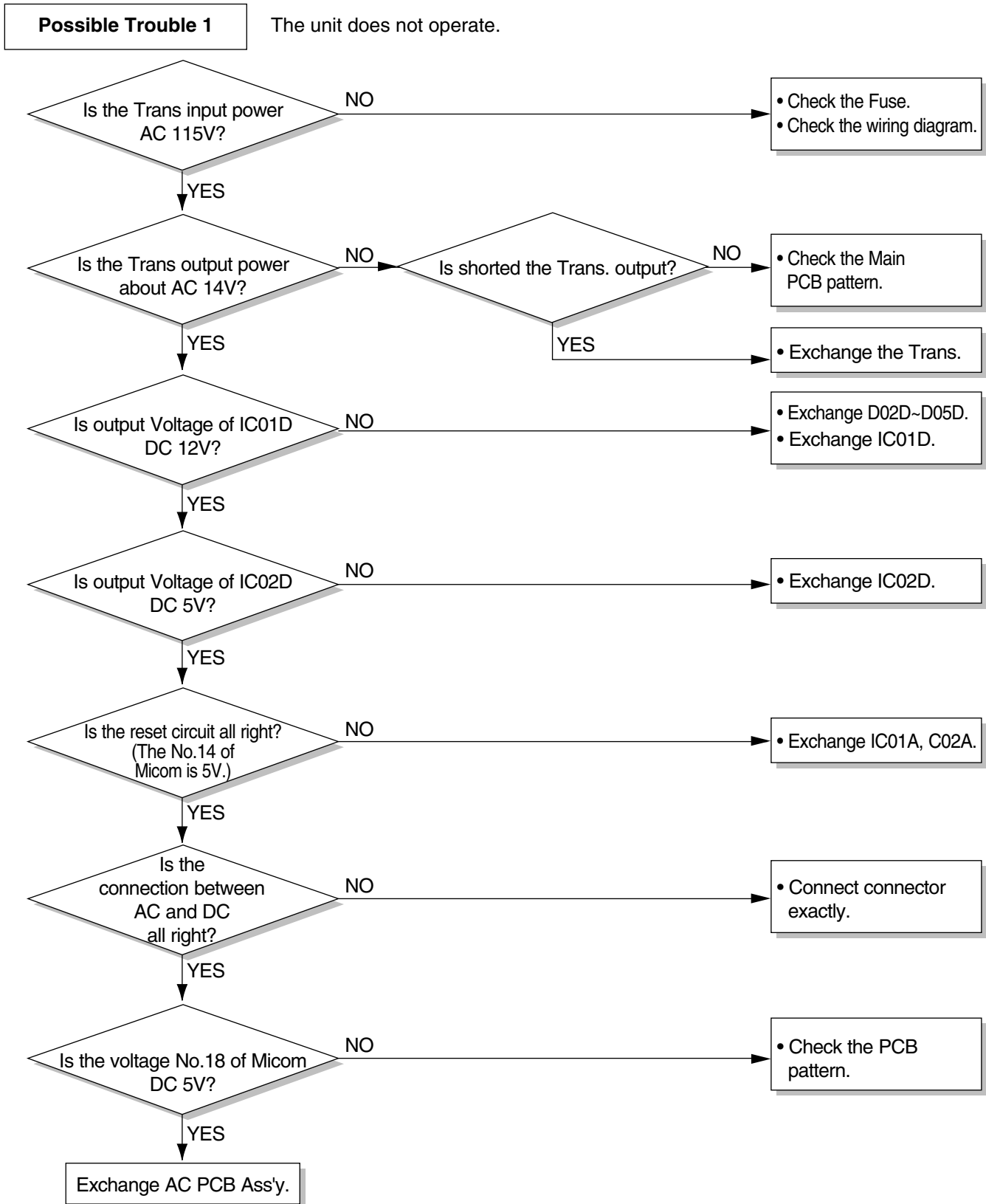

Possible Trouble 2

The compressor does not operate.

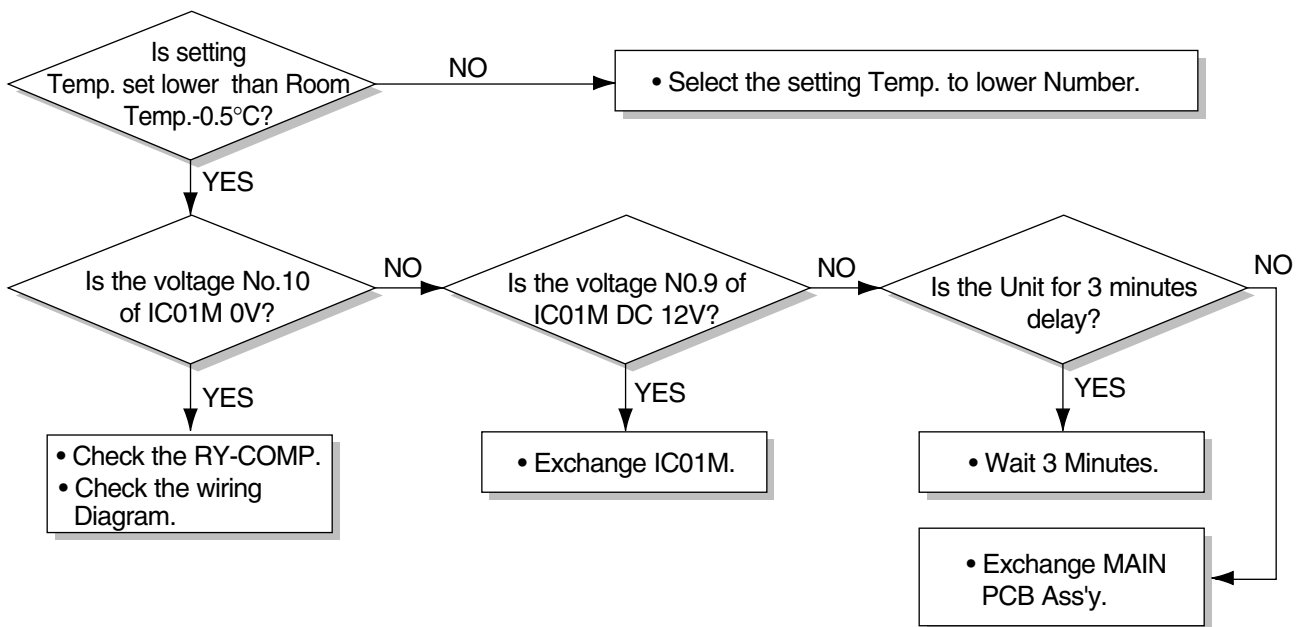

Possible Trouble 3

The compressor always operate.

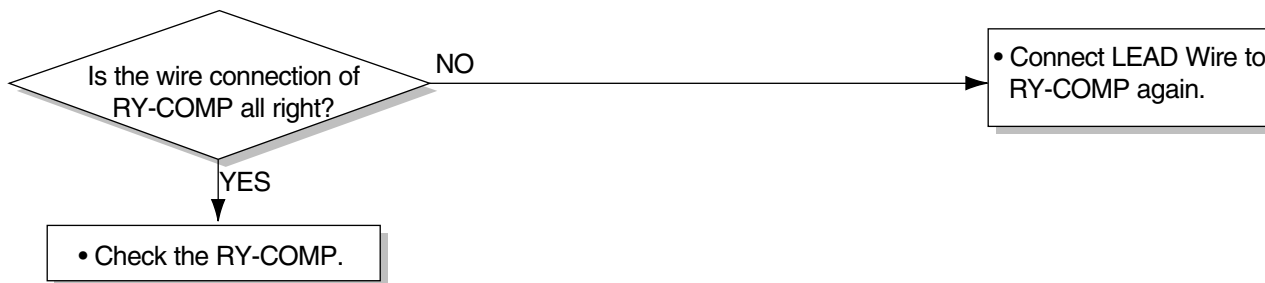

Possible Trouble 4

FAN does not operate.

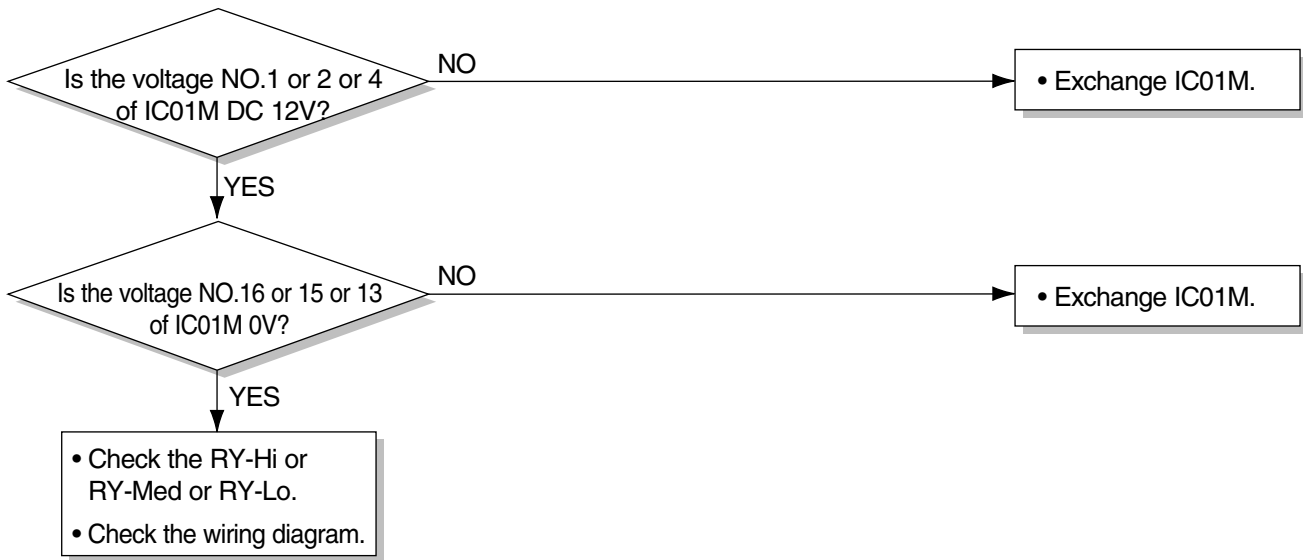
**Possible Trouble 5**

Remote controller does not operate.

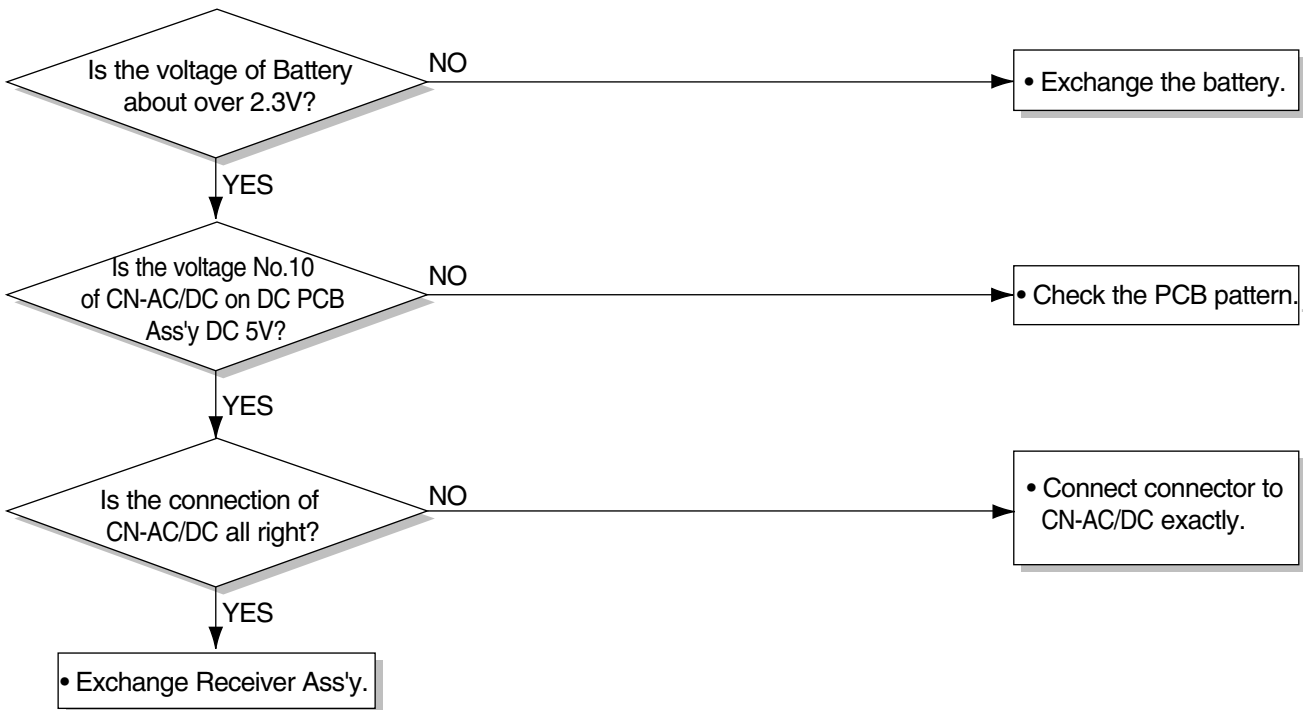

Possible Trouble 6

It displays abnormally on DC PCB Ass'y.

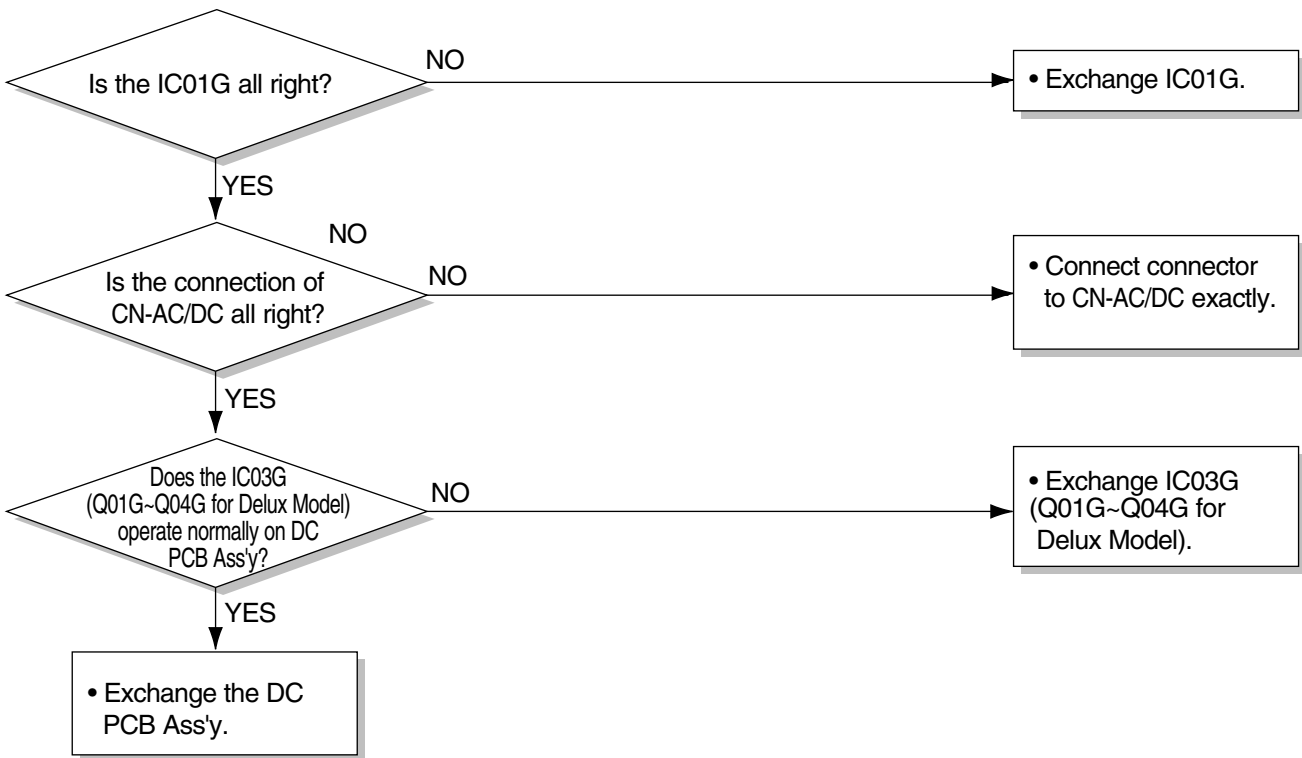

COMPLAINT	CAUSE	REMEDY
Fan motor will not run.	No power	Check voltage at outlet. Correct if none.
	Power supply cord	Check voltage to rotary switch. If none, check power supply cord. Replace cord if circuit is open.
	Rotary switch	Check switch continuity. Refer to wiring diagram for terminal identification. Replace switch if defective.
	Wire disconnected or connection loose	Connect wire. Refer to wiring diagram for terminal identification. Repair or replace loose terminal.
	Capacitor (Discharge capacitor before testing.)	Test capacitor. Replace if not within $\pm 10\%$ of manufacturer's rating. Replace if shorted, open, or damaged.
	Will not rotate	Fan blade hitting shroud or blower wheel hitting scroll. Realign assembly. Units using slinger ring for condenser fan must have $\frac{1}{4}$ to $\frac{5}{16}$ inch clearance to the base. If it hits the base, shim up the bottom of the fan motor with mounting screw(s). Check fan motor bearings; if motor shaft will not rotate, replace the motor.
Fan motor runs intermittently	Revolves on overload.	Check voltage. If not within limits, call an electrician. Test capacitor. Check bearings. Does the fan blade rotate freely? If not, replace fan motor. Pay attention to any change from high speed to low speed. If the speed does not change, replace the motor.
Fan motor noise.	Fan	If cracked, out of balance, or partially missing, replace it.
	Blower	If cracked, out of balance, or partially missing, replace it.
	Loose clamper	Tighten it.
	Worn bearings	If knocking sounds continue when running or loose, replace the motor. If the motor hums or noise appears to be internal while running, replace motor.
Compressor will not run, but fan motor runs.	Voltage	Check voltage. If not within limits, call an electrician.
	Wiring	Check the wire connections, if loose, repair or replace the terminal. If wires are off, refer to wiring diagram for identification, and replace. Check wire locations. If not per wiring diagram, correct.
	Rotary	Check for continuity, refer to the wiring diagram for terminal identification. Replace the switch if circuit is open.

COMPLAINT	CAUSE	REMEDY
Compressor will not run, but fan motor runs.	Thermostat	Check the position of knob. If not at the coldest setting, advance the knob to this setting and restart unit. Check continuity of the thermostat. Replace thermostat if circuit is open.
	Capacitor (Discharge capacitor before servicing.)	Check the capacitor. Replace if not within $\pm 10\%$ of manufacturer's rating. Replace if shorted, open, or damaged.
	Compressor	Check the compressor for open circuit or ground. If open or grounded, replace the compressor.
	Overload	Check the compressor overload, if externally mounted. Replace if open. (If the compressor temperature is high, remove the overload, cool it, and retest.)
Compressor cycles on overload.	Voltage	Check the voltage. If not within limits, call an electrician.
	Overload	Check overload, if externally mounted. Replace if open. (If the compressor temperature is high, remove the overload, cool, and retest.)
Compressor cycles on overload.	Fan motor	If not running, determine the cause. Replace if required.
	Condenser air flow restriction	Remove the cabinet. Inspect the interior surface of the condenser; if restricted, clean carefully with a vacuum cleaner (do not damage fins) or brush. Clean the interior base before reassembling.
	Condenser fins (damaged)	If condenser fins are closed over a large area on the coil surface, head pressures will increase, causing the compressor to overload. Straighten the fins or replace the coil.
Compressor cycles on overload.	Capacitor	Test capacitor.
	Wiring	Check the terminals. If loose, repair or replace.
	Refrigerating system	Check the system for a restriction.
Insufficient cooling or heating	Air filter	If restricted, clean or replace.
	Exhaust damper door	Close if open.
	Unit undersized	Determine if the unit is properly sized for the area to be cooled.
Excessive noise	Blower or fan	Check the set screw or clamp. If loose or missing, correct. If the blower or fan is hitting air guide, rearrange the air handling parts.
	Copper tubing	Remove the cabinet carefully and rearrange tubing not to contact cabinet, compressor, shroud, and barrier.

5.2 ELECTRONIC CONTROL DEVICE

MODEL : WM-8031, WM-1031, WM-1231, HBLG8003R, HBLG1003R, L1204R, R1200E

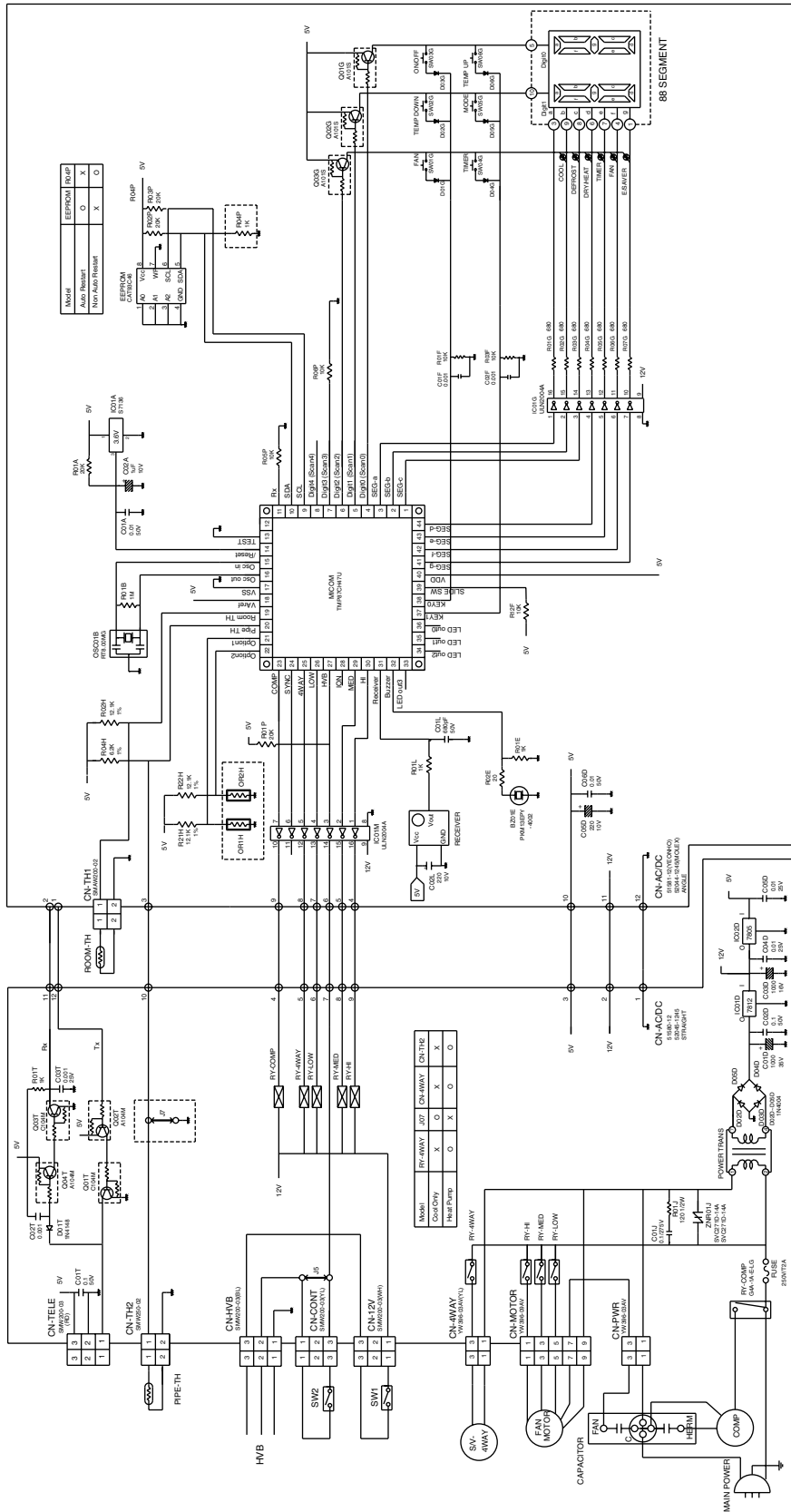

5.3 COMPONENTS LOCATION(FOR AC P.C.B ASM)

MODEL : WM-8031, WM-1031, WM-1231, HBLG8003R, HBLG1003R, L1204R, R1200E

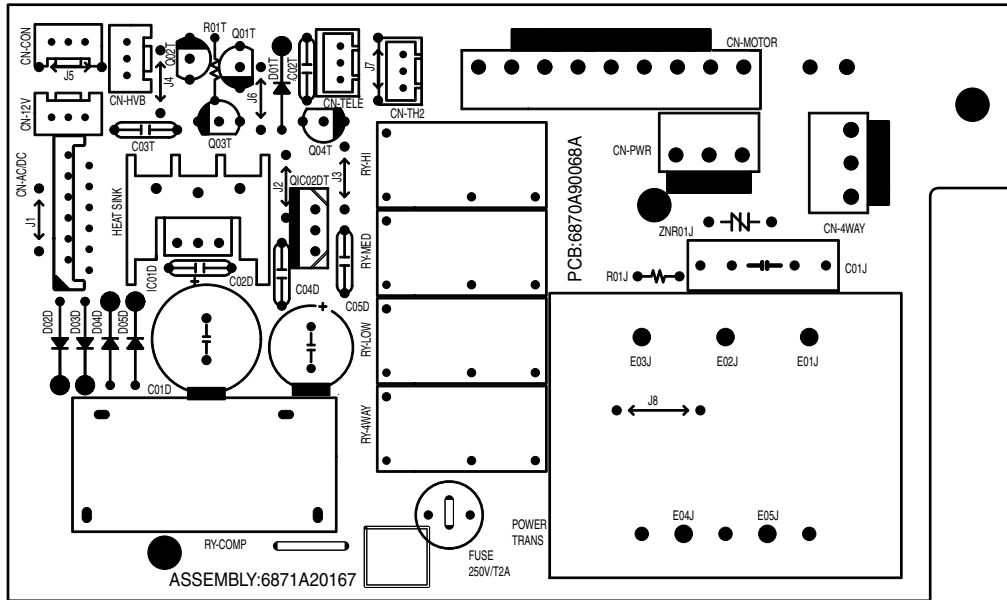

5.4 COMPONENTS LOCATION(FOR DC P.C.B ASM)

MODEL : WM-8031, WM-1031, WM-1231, HBLG8003R, HBLG1003R, L1204R, R1200E

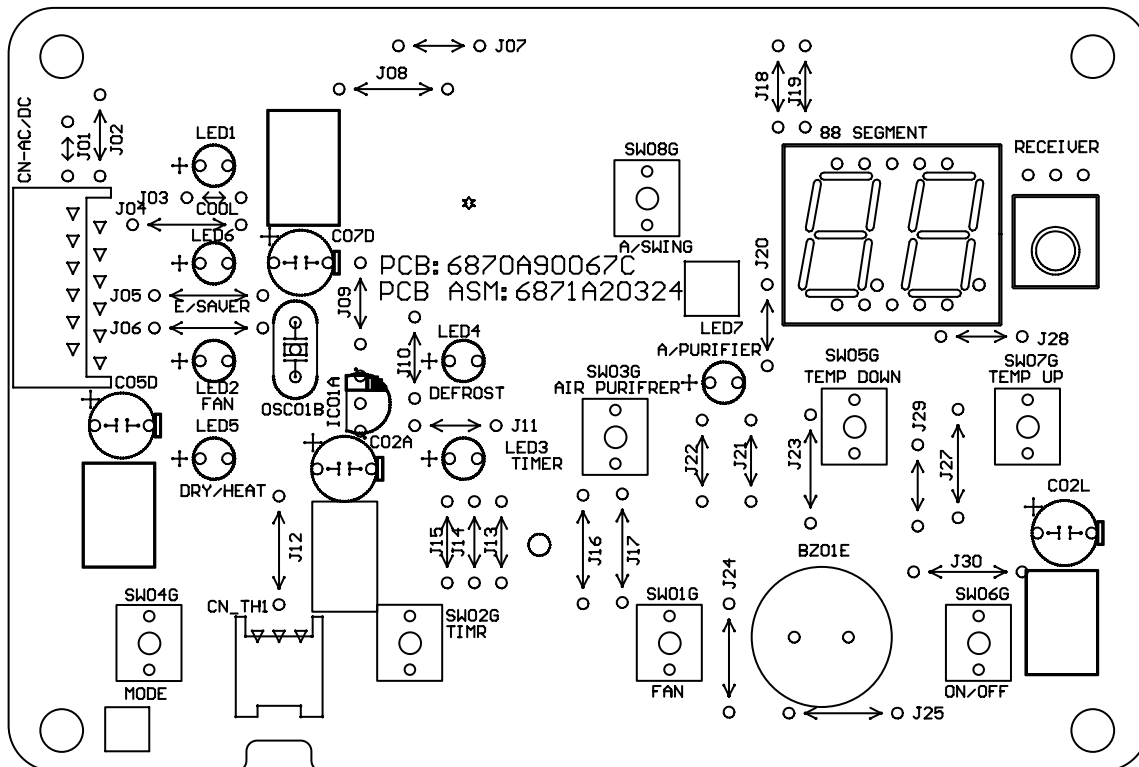

6. EXPLODED VIEW

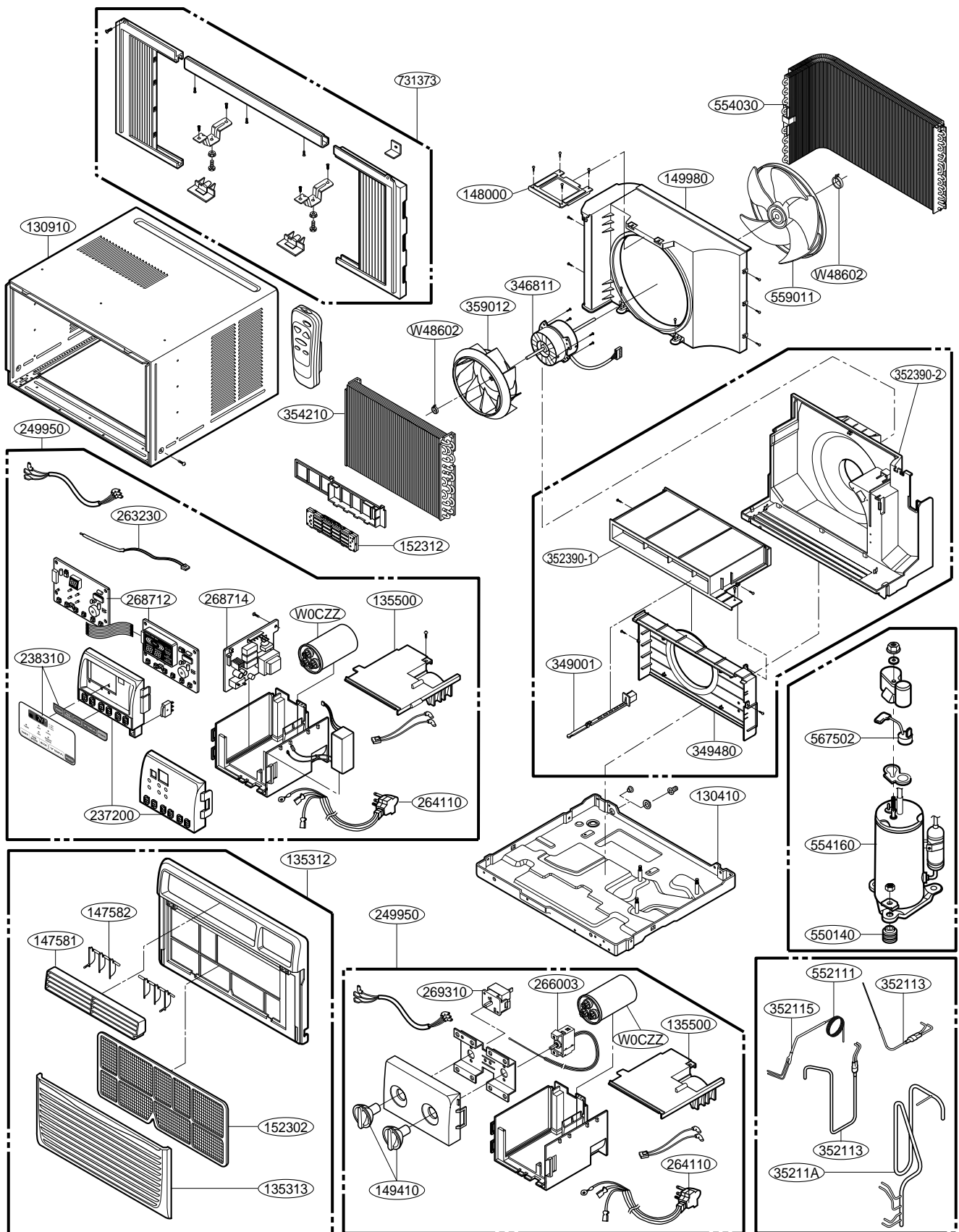

7. REPLACEMENT PARTS LIST

R: Service Parts
N: Non Service Parts

LOCATION NO.	DESCRIPTION	PART NO.					REMARK
		WR-8030	WM-0831	WM-1031	WR-1230 R1200M	WM-1231 L1204R	
130410	BASE ASSEMBLY,SINGLE	3041A20021V	3041A20021V	3041A20021N	3041A20020L	3041A20020L	R
130910	CABINET ASSEMBLY,SINGLE	3091AR2317K	3091AR2317K	3091AR2317K	3091A10032M	3091A10032M	R
135312	GRILLE ASSEMBLY,FRONT(SINGLE)	3531A20097A	3531A20097A	3531A20097A	3531A20098A	3531A20098A	R
135303	GRILLE,INLET	-	-	-	3530A20037A	3530A20037A	R
135313	GRILLE ASSEMBLY,INLET	3530A20038A	3530A20038A	3530A20038A	-	-	R
135500	COVER,CONTROL(INDOOR)	3550A30194A	3550A30114A	3550A30114A	3550A30194A	3550A30114A	R
237200	PANEL,CONTROL	3720A10113A	3720A10111A	3720A10111A	3720A10113A	3720A10111A	R
147581	LOUVER,HORIZONTAL	4758A20019A	4758A20019A	4758A20019A	4758A20018A	4758A20018A	R
147582-1	LOUVER,VERTICAL	4758A20040A	4758A20040A	4758A20040A	4758A20041A	4758A20041A	R
147582-2	LOUVER,VERTICAL	4758A20040B	4758A20040B	4758A20040B	4758A20041B	4758A20041B	R
148000	BRACE	4800A30002A	4800A30002A	4800A30002A	4800A30002B	4800A30002B	R
149410	KNOBS ASSEMBLY	4941A30020A	-	-	4941A30020A	-	R
149980	SHROUD	4998A10023A	4998A10023A	4998A10012A	4998A10016A	4998A10016A	R
152302	FILTER(MECH),A/C	5231A20006A	5231A20006A	5231A20006A	5231A20007A	5231A20007A	R
269310	THERMOSTAT	2H01109M	-	-	2H01109M	-	R
238310	ESCUTCHEON	-	3831A10021J	3831A10021J	-	3831A10021J	R
249950	CONTROL BOX ASSEMBLY,SINGLE	4995A20279A	4995A20278A	4995A20278B	4995A20279C	4995A20278C	R
263230	THERMISTOR	-	6323A20004D	6323A20004D	-	6323A20004D	R
264110	POWER CORD ASSEMBLY	6411A20011T	6411A20011F	6411A20011R	6411A20011U	6411A20011H	R
266003	SWITCH, ROTARY	2H00598E	-	-	2H00598E	-	R
267110	REMOTE CONTROLLER	-	6711A20034G	6711A20034G	-	6711A20034G	R
268712	PWB(PCB) ASSEMBLY,DISPLAY	-	6871A20324B	6871A20324B	-	6871A20324B	R
268714	PWB(PCB) ASSEMBLY,MAIN	-	6871A20167C	6871A20167C	-	6871A20167C	R
346811	MOTOR ASSEMBLY,SINGLE	4681A20069M	4681A20069G	4681A20069H	4681A20069P	4681A20069J	R
349001	DAMPER,VENTILATION	4900A20003A	4900A20003A	4900A20003A	4900A20002A	4900A20002A	R
349480	ORIFICE	4948A10014A	4948A10014A	4948A10014A	4948A10015A	4948A10015A	R
352113	TUBE ASSEMBLY,DISCHARGE SINGLE	5211A20708B	5211A20708B	5211A10074J	5211A10074K	5211A10074K	R
352115	TUBE ASSEMBLY,EVAPORATOR IN	5211A20559K	5211A20559K	5211A20470F	5211A20559N	5211A20559N	R
352390-2	AIR GUIDE ASSEMBLY	5239A20012A	5239A20012A	5239A20012A	5238A20008A	5238A20008A	R
352390-1	AIR GUIDE ASSEMBLY	5239A20005A	5239A20005A	5239A20005A	5239A20004A	5239A20004A	R
354210	EVAPORATOR ASSEMBLY,FIRST	5421A10026B	5421A10026B	5421A10026C	5421A20130A	5421A20130A	R
559012	FAN,TURBO	5900A20020A	5900A20020A	5900A20020A	5900A20019C	5900A20019C	R
550140	ISOLATOR,COMP	4830AR4335A	4830AR4335A	4830AR4335A	4830AR4335A	4830AR4335A	R
552111	TUBE ASSEMBLY, CAPILLARY)	5211A30275N	5211A30275N	5211A30275M	5211A30275P	5211A30275P	R
554030	CONDENSER ASSEMBLY,FIRST	5403A20092B	5403A20092B	-	5403AR2921H	5403AR2921H	R
554031	CONDENSER ASSEMBLY,BENT	-	-	5403A20043M	-	-	R
554160	COMPRESSOR	5416A20014B	5416A20014B	2520UKLC2CA	2520UKFC2AA	2520UKFC2AA	R
559010	FAN ASSEMBLY,AXIAL	5900AR1167B	5900AR1167B	5900AR1167B	5900A10009B	5900A10009B	R
567502	O.L.P	6750A30001N	6750A30001N	6750U-L031A	6750U-L029A	6750U-L029A	R
731373	INSTALL PARTS ASSEMBLY,SINGLE	3127A10015B	3127A10015B	3127A10015B	3127A10015G	3127A10015G	R
35211A	TUBE ASSEMBLY,SUCTION SINGLE	5211A20228R	5211A20228R	5211A20228S	5211A20441F	5211A20441F	R
W0CZZ	CAPACITOR	6120AR2359V	6120AR2359V	0CZZA20001N	0CZZA20001N	0CZZA20001N	R
W48602	CLAMP,SPRING	3H02932B	3H02932B	3H02932B	3H02932B	3H02932B	R

NOTE) *Please ensure GCSC since these parts may be changed depending upon the buyer's request.
(GCSC WEBSITE <http://biz.LGservice.com>)

R: Service Parts
N: Non Service Parts

LOCATION NO.	DESCRIPTION	PART NO.				REMARK
		HBLG8003R	HBLG1003R	WR-1030	R1200E	
130410	BASE ASSEMBLY,SINGLE	3041A20021V	3041A20021N	3041A20021N	3041A20020L	R
130910	CABINET ASSEMBLY,SINGLE	3091AR2317K	3091AR2317K	3091AR2317K	3091A10032M	R
135312	GRILLE ASSEMBLY,FRONT(SINGLE)	3531A20160A	3531A20160A	3531A20097A	3531A20161B	R
135303	GRILLE,INLET	3530A20075A	3530A20075A	3530A20038A	3530A20076A	R
135500	COVER	3550A30114A	3550A30114A	3550A30194A	3550A30114A	R
147581	LOUVER,HORIZONTAL	4758A20019A	4758A20019A	4758A20019A	4758A20018A	R
147582-1	LOUVER,VERTICAL	4758A20040B	4758A20040B	4758A20040A	4758A20041A	R
147582-2	LOUVER,VERTICAL	4758A20040A	4758A20040A	4758A20040B	4758A20041B	R
148000	BRACE	4800A30002A	4800A30002A	4800A30002A	4800A30002B	R
149410	KNOB ASSEMBLY	-	-	4941A30020A	-	R
149980	SHROUD	4998A10023A	4998A10012A	4998A10012A	4998A10016A	R
152302	FILTER ASSEMBLY,AIR CLEANER	5231A20006A	5231A20006A	5231A20006A	5231A20007A	R
237200	PANEL, CONTROL	3720A10111A	3720A10111A	3720A10113A	3720A10111A	R
238310	ESCUTCHEON	3831A10021E	3831A10021E	-	3831A10021J	R
269310	THERMOSTAT	-	-	2H01109M	-	R
249950	CONTROL BOX ASSEMBLY,SINGLE	4995A20194V	4995A20194W	4995A20279B	4995A20278C	R
263230	THERMISTOR ASSEMBLY	6323A20004D	6323A20004D	-	6323A20004D	R
264110	POWER CORD ASSEMBLY	6411A20011F	6411A20011R	6411A20011V	6411A20011H	R
266003	SWITCH, ROTARY	-	-	2H00598E	-	R
267110	REMOTE CONTROLLER ASSEMBLY	6711A90019C	6711A90019C	-	6711A20034C	R
268714	PWB(PCB) ASSEMBLY,MAIN(AC)	6871A20167C	6871A20167C	-	6871A20324B	R
268714	PWB(PCB) ASSEMBLY,MAIN(DC)	6871A20324A	6871A20324A	-	6871A20167C	R
346811	MOTOR ASSEMBLY,SINGLE	4681A20069G	4681A20069H	4681A20069N	4681A20069J	R
349001	DAMPER,VENTILATION	4900A20003A	4900A20003A	4900A20003A	4900A20002A	R
349480	ORIFICE	4948A10014A	4948A10014A	4948A10014A	4948A10015A	R
352113	TUBE ASSEMBLY,DISCHARGE SINGLE	5211A20708B	5211A10074J	5211A10074J	5211A10074K	R
352115	TUBE ASSEMBLY,EVAPORATOR IN	5211A20559K	5211A20470F	5211A20470F	5211A20559N	R
35211A	TUBE ASSEMBLY,SUCTION SINGLE	5211A20228R	5211A20228S	5211A20228S	5211A20441F	R
352390-1	AIR GUIDE ASSEMBLY	5239A20005A	5239A20005A	5239A20005A	5238A20008A	R
352390-2	AIR GUIDE ASSEMBLY	5239A20012A	5239A20012A	5239A20012A	5239A20004A	R
354210	EVAPORATOR ASSEMBLY,FIRST	5421A10026B	5421A10026C	5421A10026C	-	R
559012	FAN,TURBO	5900A20020A	5900A20020A	5900A20020A	5900A20019C	R
550140	ISOLATOR,COMP	4830AR4335A	4830AR4335A	4830AR4335A	4830AR4335A	R
552111	TUBE ASSEMBLY , CAPILLARY	5211A30275N	5211A30275M	5211A30275M	5424AR3448G	R
554030	CONDENSER ASSEMBLY,FIRST	5403A20092B	-	-	5403AR2921H	R
554031	CONDENSER ASSEMBLY,BENT	-	5403A20043M	5403A20043M	-	R
554160	COMPRESSOR	5416A20014B	2520UCDK004	2520UCDK004	2520UKFC2AA	R
559010	FAN ASSEMBLY,AXIAL	5900AR1167B	5900AR1167B	5900AR1167B		R
567502	O.L.P	6750A30001N	6750U-L031A	6750U-L031A	6750U-L029A	R
731373	INSTALL PARTS ASSEMBLY, SINGLE	3127A10015B	3127A10015B	3127A10015B	3127A10015G	R
W0CZZ	CAPACITOR,DRAWING	6120AR2359V	0CZZA20001N	0CZZA20001N	0CZZA20001N	R
W48602	CLAMP,SPRING	3H02932B	3H02932B	3H02932B	3H02932B	R

NOTE) *Please ensure GCSC since these parts may be changed depending upon the buyer's request.
(GCSC WEBSITE <http://biz.LGservice.com>)

MEMO

A series of horizontal dotted lines for writing.

MEMO

A series of horizontal dotted lines for writing.



LG Electronics Inc.